



HISTORIC PRESERVATION COMMISSION

Marc Elrich
County Executive

Robert K. Sutton
Chairman

Date: June 10, 2022

MEMORANDUM

TO: Mitra Pedoeem
Department of Permitting Services

FROM: Dan Bruechert
Historic Preservation Section
Maryland-National Capital Park & Planning Commission

SUBJECT: Historic Area Work Permit #991955 - Kiosk and Signage

The Montgomery County Historic Preservation Commission (HPC) has reviewed the attached application for a Historic Area Work Permit (HAWP). This application was **Approved** by HPC Staff.

The HPC staff has reviewed and stamped the attached construction drawings.

THE BUILDING PERMIT FOR THIS PROJECT SHALL BE ISSUED CONDITIONAL UPON ADHERENCE TO THE ABOVE APPROVED HAWP CONDITIONS AND MAY REQUIRE APPROVAL BY DPS OR ANOTHER LOCAL OFFICE BEFORE WORK CAN BEGIN.

Applicant: Sandy Spring Monthly Meeting
Address: 17715 Meeting House Rd., Sandy Spring

This HAWP approval is subject to the general condition that the applicant will obtain all other applicable Montgomery County or local government agency permits. After the issuance of these permits, the applicant must contact this Historic Preservation Office if any changes to the approved plan are made. Once work is complete the applicant will contact Dan Bruechert at 301.563.3400 or dan.bruechert@montgomeryplanning.org to schedule a follow-up site visit.



APPROVED
 Montgomery County
 Historic Preservation Commission



REVIEWED
 By Dan.Bruechert at 11:59 am, Jun 10, 2022

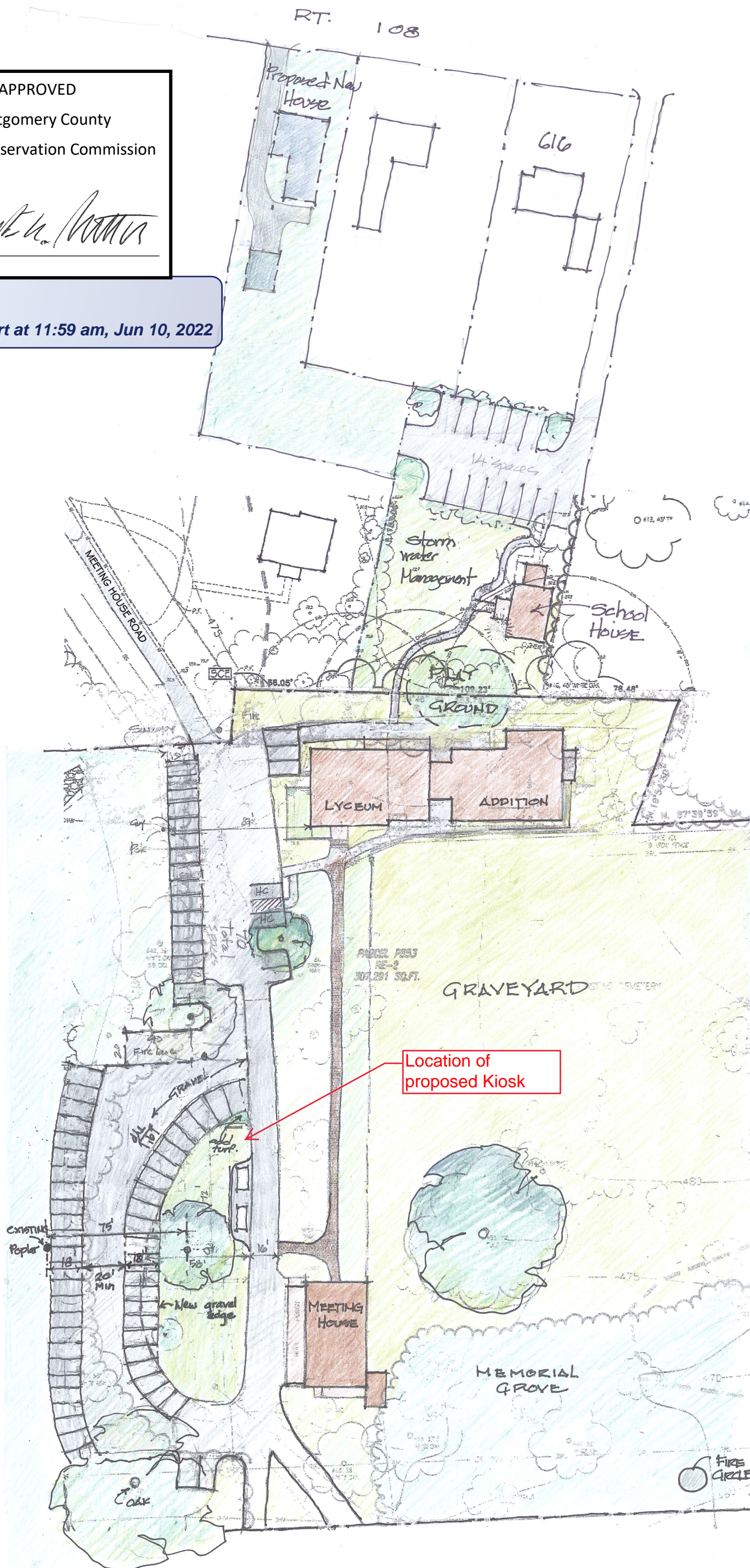

Location of proposed Kiosk

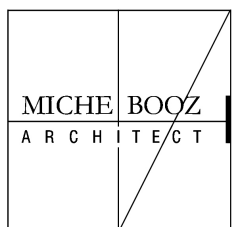

PROPOSED SITE PLAN

1" = 60'

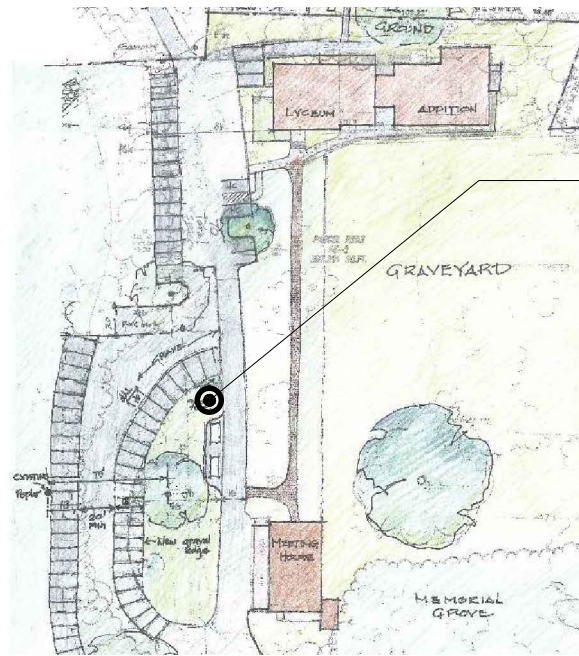

PROPOSED KIOSK LOCATION

1 SITE PLAN
N.T.S.

PERMANENT TEXT
(EXACT TEXT NOT YET DETERMINED)

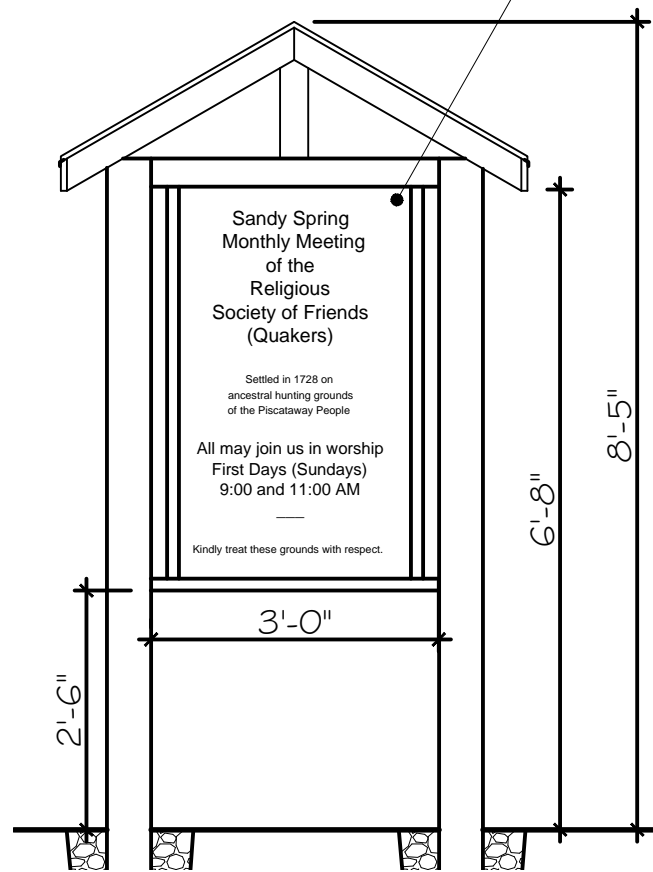

2 FACING ENTRY FROM 108
1/2" = 1'-0"

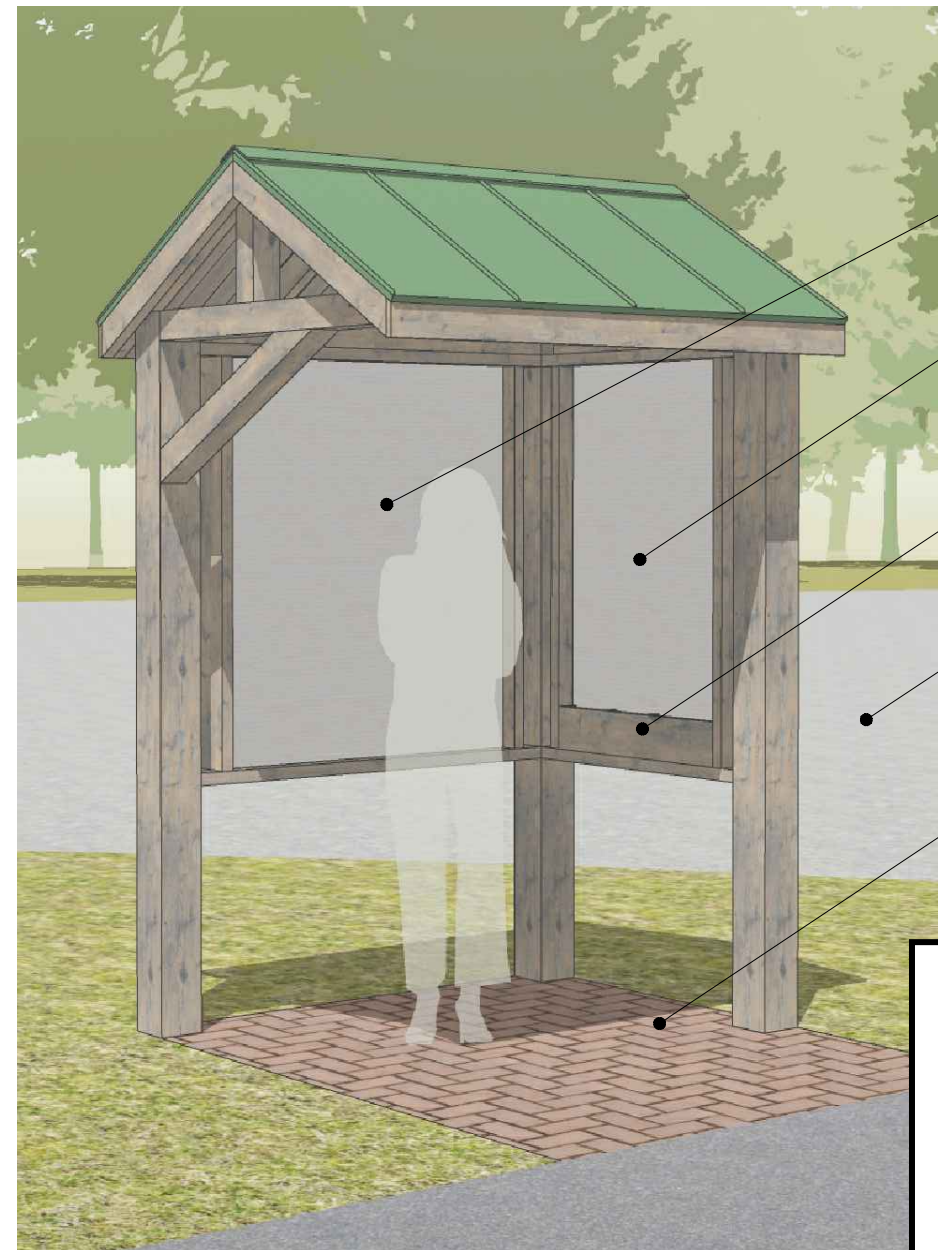

CHANGEABLE DISPLAY

PERMANENT SITE MAP

LITERATURE HOLDER

EXG. GRAVEL PARKING LOT

BRICK OR FLAGSTONE SURFACE

APPROVED
Montgomery County
Historic Preservation Commission
Ronald H. [Signature]

3 VIEW FROM MEETINGHOUSE RD.

REVIEWED

By Dan.Bruechert at 12:00 pm, Jun 10, 2022

APPROVED
 Montgomery County
 Historic Preservation Commission



REVIEWED
 By Dan.Bruechert at 12:00 pm, Jun 10, 2022

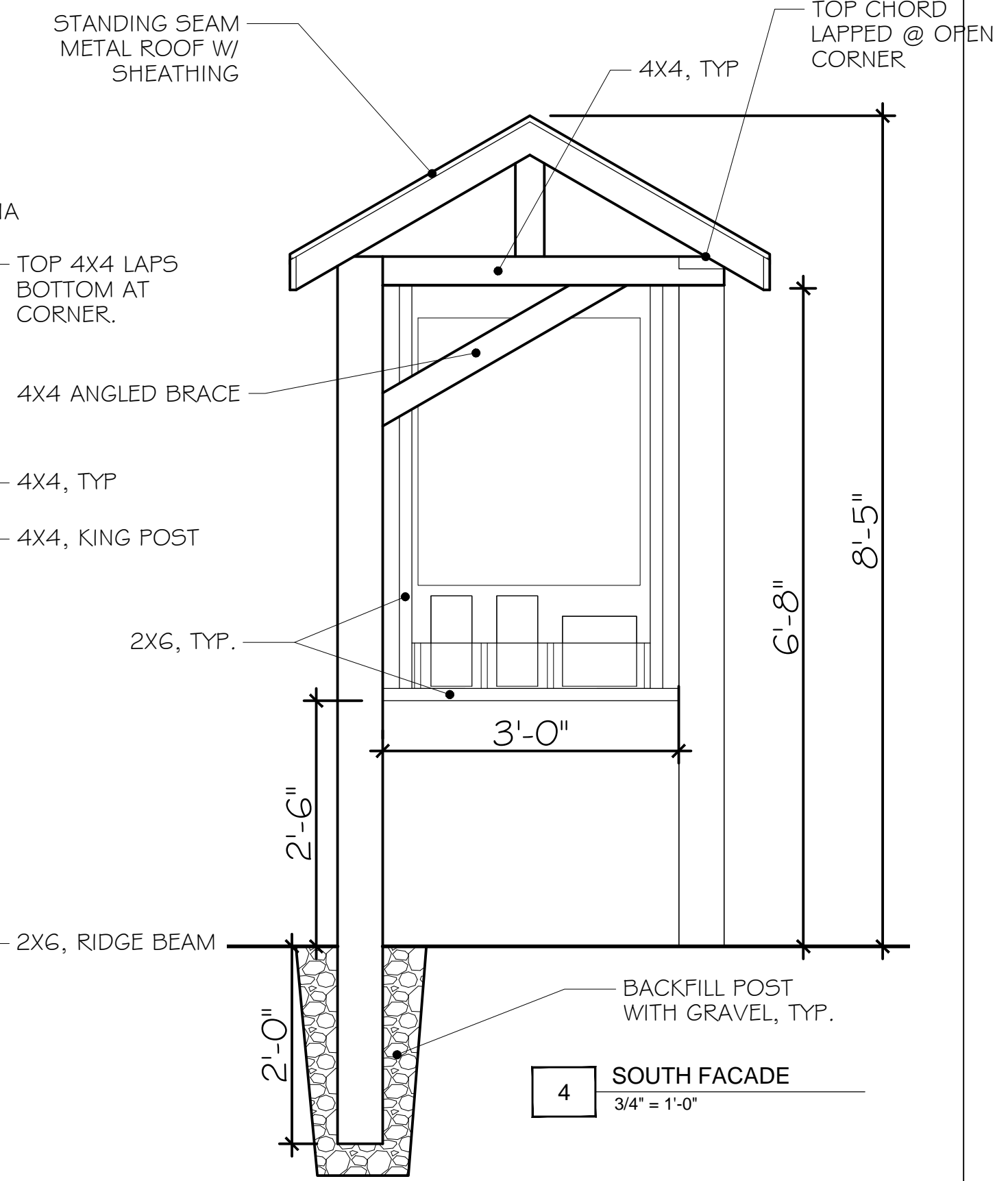
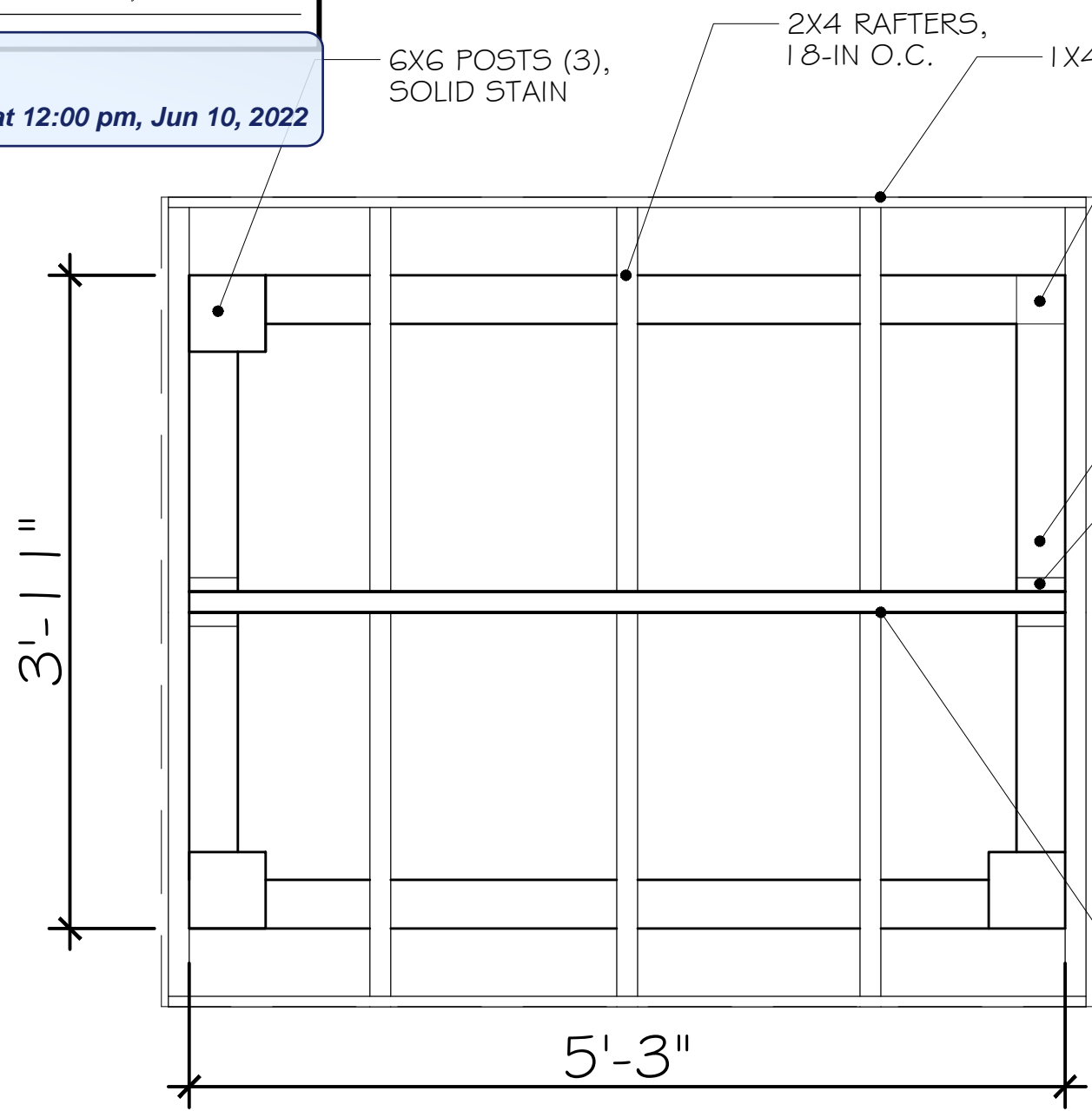

1 KIOSK FRAMING PLAN
 1" = 1'-0"

4 SOUTH FACADE
 3/4" = 1'-0"

APPROVED
 Montgomery County
 Historic Preservation Commission



REVIEWED
 By Dan.Bruechert at 12:00 pm, Jun 10, 2022

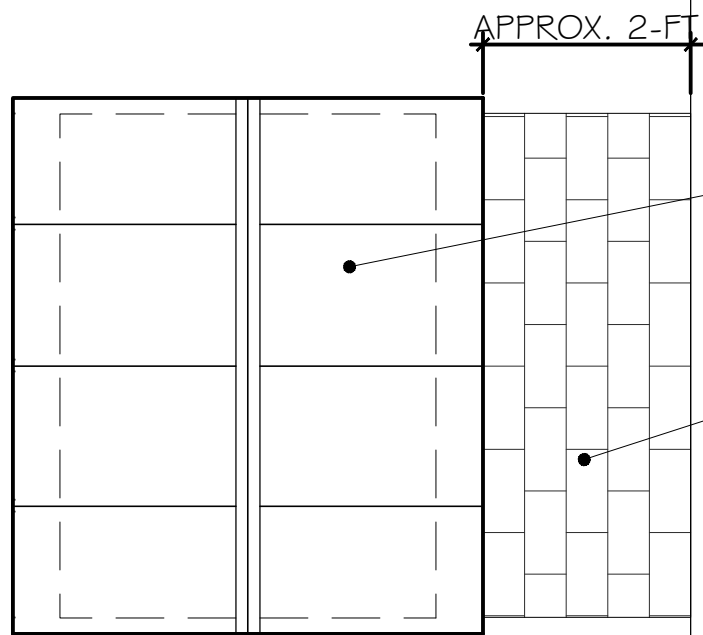

STANDING SEAM METAL ROOF

BRICK PAVERS EXTEND TO MEETING HOUSE ROAD.

CHANGEABLE INSPIRATIONAL DISPLAY W/ PLEXI. COVER

1 ROOF PLAN

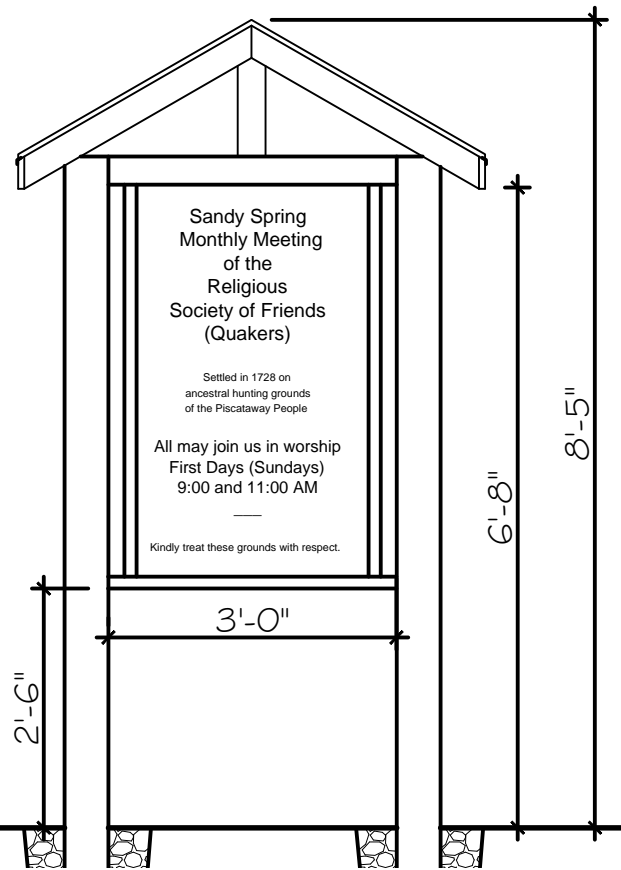

3 NORTH ELEVATION
 FACING ENTRY FROM 108

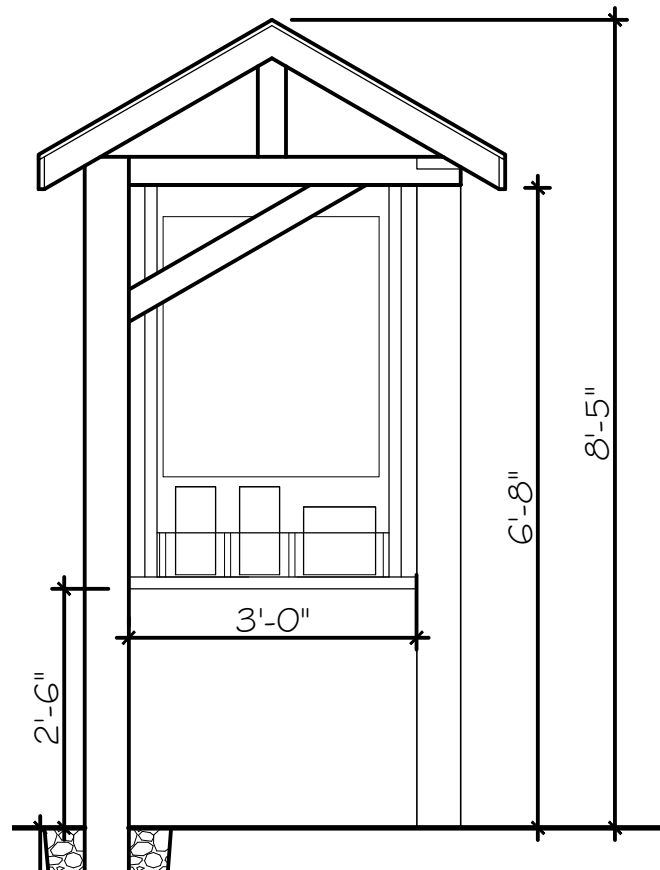

4 SOUTH ELEVATION

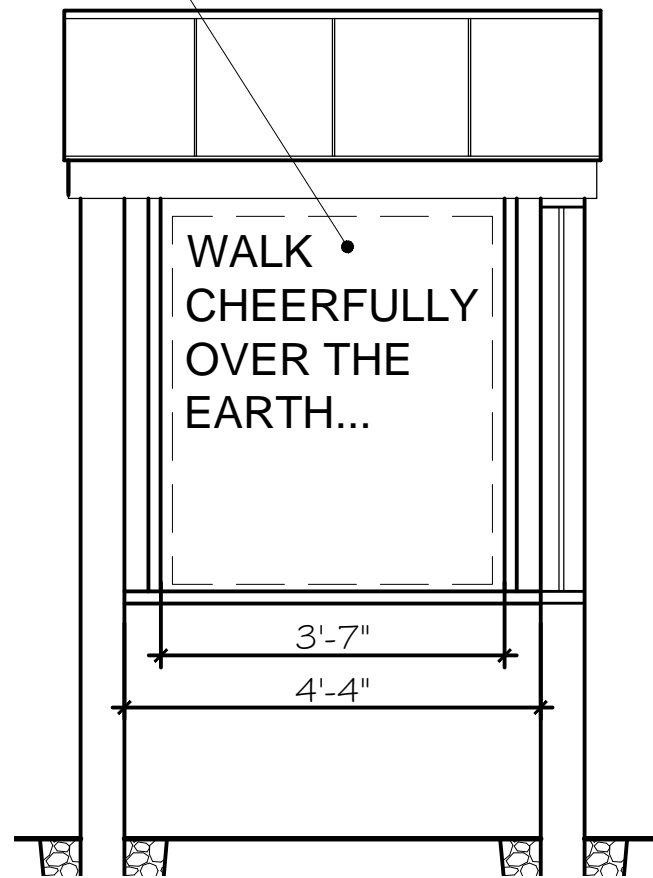

5 FRONT (EAST)
 FACING MEETINGHOUSE

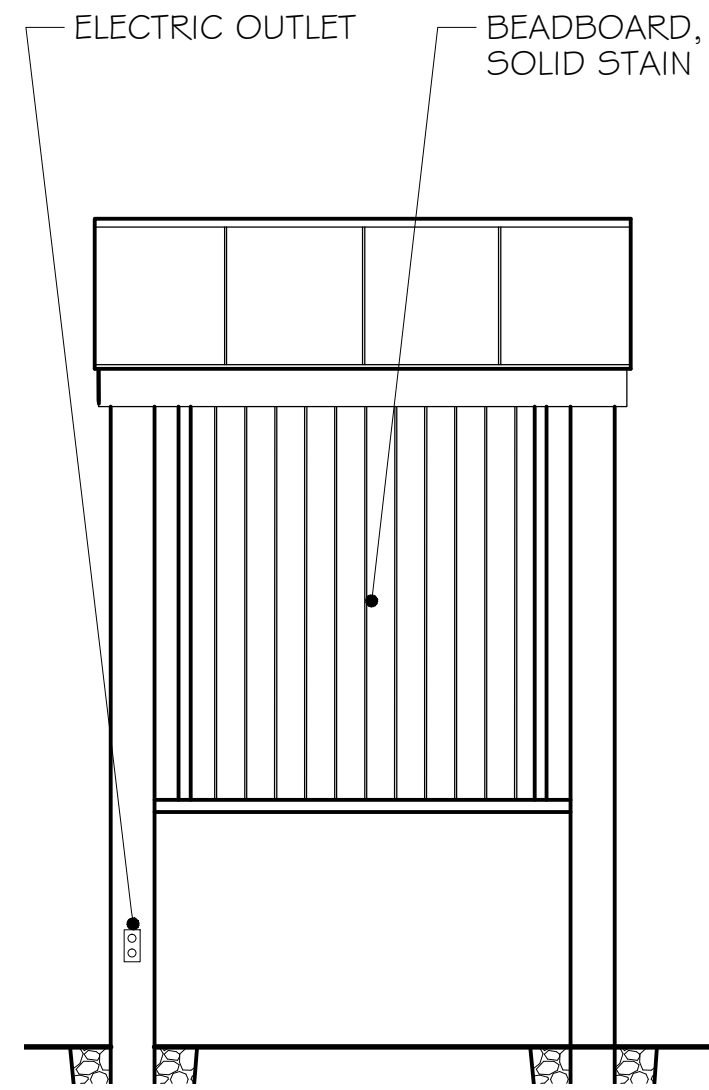

6 BACK (WEST)
 FACING PARKING LOT