



## HISTORIC PRESERVATION COMMISSION

Marc Elrich  
*County Executive*

Sandra I. Heiler  
*Chairman*

Date: January 24, 2020

### MEMORANDUM

TO: Hadi Mansouri  
Department of Permitting Services

FROM: Michael Kyne  
Historic Preservation Section  
Maryland-National Capital Park & Planning Commission

SUBJECT: Historic Area Work Permit #898441: Window replacement

---

The Montgomery County Historic Preservation Commission (HPC) has reviewed the attached application for a Historic Area Work Permit (HAWP). This application was **Approved** at the January 22, 2020 HPC meeting.

The HPC staff has reviewed and stamped the attached construction drawings.

THE BUILDING PERMIT FOR THIS PROJECT SHALL BE ISSUED CONDITIONAL UPON ADHERENCE TO THE ABOVE APPROVED HAWP CONDITIONS AND MAY REQUIRE APPROVAL BY DPS OR ANOTHER LOCAL OFFICE BEFORE WORK CAN BEGIN.

Applicant: Barney Long (Karlen Murry, Agent)  
Address: 308 Lincoln Ave., Takoma Park

This HAWP approval is subject to the general condition that the applicant will obtain all other applicable Montgomery County or local government agency permits. After the issuance of these permits, the applicant must contact this Historic Preservation Office if any changes to the approved plan are made. Once work is complete the applicant will contact Michael Kyne at 301.563.3400 or [michael.kyne@montgomeryplanning.org](mailto:michael.kyne@montgomeryplanning.org) to schedule a follow-up site visit.



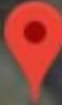
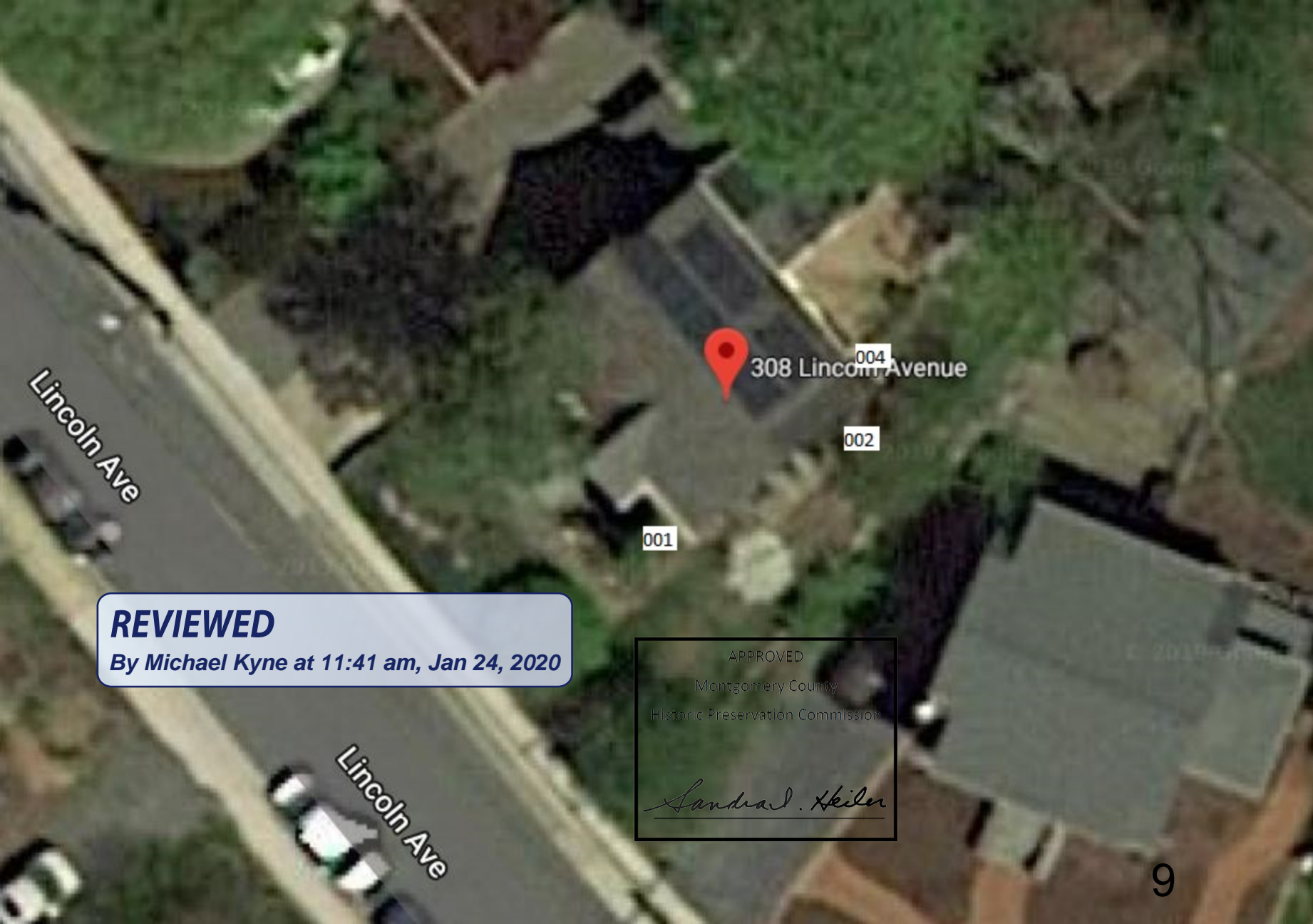

308 Lincoln Avenue

004

002

001

Lincoln Ave

Lincoln Ave

**REVIEWED**  
By Michael Kyne at 11:41 am, Jan 24, 2020

APPROVED  
Montgomery County  
Historic Preservation Commission  
*Sandra L. Heiler*



# Itemized Order Receipt

dba: Renewal by Andersen of the Capital Region

Legal Name: Renewal by Andersen LLC

DC:420215000125,VA:2705155684,MD:121441

2814-A Merrilee Drive, Fairfax, VA 22031 | 8265 Patuxent Range Road Suite A, Jessup, MD 20794,

Phone: DCVA:703-641-5400, MD:301-483-7340 | Fax: N/A | CapitalOrders@AndersenCorp.com

Barney Long

308 Lincoln Ave

Takoma Park, MD 20912

H: (646)415-2808

ID#:	ROOM:	SIZE:	DETAILS:
#	Project	0 W 0 H	<b>Misc:</b> Misc - Scope of Work, Remove and replace original rope & weight windows and basement door. Standard-sized basement door. Historic preservation required before order release. This is an historic preservation-managed property...In addition to the above elements, many important Scope of Work details are also covered on the "What to Expect" and "Installation Selection sheet" Documents.
#	CO1	0 W 0 H	<b>Misc:</b> Misc - Change Order, CO1 - 1. Remove Door from order. Add, Delete, or Change Line Item Detail/Spec Sheets, as well.
001	B. FR	33 W 37 H	<b>Window:</b> Double-Hung (DG), Equal, Slope Sill, Insert Frame, Traditional Checkrail, Exterior White, Interior White, <b>Glass:</b> All Sash: High Performance SmartSun Glass, No Pattern, <b>Hardware:</b> White, Standard Color Finger Lifts, <b>Screen:</b> TruScene with Exterior Color Match, Half Screen, <b>Grille Style:</b> Full Divided Light (FDL with spacer), <b>Grille Pattern:</b> All Sash: Colonial 3w x 2h, <b>Misc:</b> Omit Interior Trim, See Installation Method Selection Sheet.
002	B. B1	32 W 54 H	<b>Window:</b> Double-Hung (DG), Equal, Slope Sill, Insert Frame, Traditional Checkrail, Exterior White, Interior White, <b>Glass:</b> All Sash: High Performance SmartSun Glass, No Pattern, <b>Hardware:</b> White, Standard Color Finger Lifts, <b>Screen:</b> TruScene with Exterior Color Match, Half Screen, <b>Grille Style:</b> Full Divided Light (FDL with spacer), <b>Grille Pattern:</b> All Sash: Colonial 3w x 2h, <b>Misc:</b> Omit Interior Trim, See Installation Method Selection Sheet.

**REVIEWED**  
By Michael Kyne at 11:41 am, Jan 24, 2020

APPROVED  
Montgomery County  
Historic Preservation Commission  
*Sandra J. Heiler*



# Itemized Order Receipt

dba: Renewal by Andersen of the Capital Region  
 Legal Name: Renewal by Andersen LLC  
**DC:420215000125,VA:2705155684,MD:121441**  
 2814-A Merrilee Drive, Fairfax, VA 22031 | 8265 Patuxent Range Road Suite A, Jessup, MD 20794,  
 Phone: DCVA:703-641-5400, MD:301-483-7340 | Fax: N/A | CapitalOrders@AndersenCorp.com

**Barney Long**  
 308 Lincoln Ave  
 Takoma Park, MD 20912  
 H: (646)415-2808

ID#:	ROOM:	SIZE:	DETAILS:
004	B. FR	33 W 37 H	<b>Window:</b> Double-Hung (DG), Equal, Slope Sill, Insert Frame, Traditional Checkrail, Exterior White, Interior White, <b>Glass:</b> All Sash: High Performance SmartSun Glass, No Pattern, <b>Hardware:</b> White, Standard Color Finger Lifts, <b>Screen:</b> TruScene with Exterior Color Match, Half Screen, <b>Grille Style:</b> Full Divided Light (FDL with spacer), <b>Grille Pattern:</b> All Sash: Colonial 3w x 2h, <b>Misc:</b> Omit Interior Trim, See Installation Method Selection Sheet.
<b>WINDOWS: 3    PATIO DOORS: 0    SPECIALTY: 0    MISC: 2</b>			

**REVIEWED**  
 By Michael Kyne at 11:41 am, Jan 24, 2020

APPROVED  
 Montgomery County  
 Historic Preservation Commission



*Renewal by Andersen is committed to our customers' safety by complying with the rules and lead-safe work practices specified by the EPA.*

# What are Renewal by Andersen® windows made of?

All of our windows are made of Fibrex® material, a revolutionary composite made from reclaimed wood fiber blended with a polymer. This gives our windows the strength and durability of wood and the low-maintenance features of vinyl, while greatly limiting thermal transmittance found in other window materials such as metal.

Unlike many other window materials, Fibrex composite material won't flake, rust, blister, peel, crack, pit, or corrode.<sup>1</sup> It is also two times stronger than vinyl and resists warping and bowing. Never worry about scraping or painting your windows again.

## REVIEWED

By Michael Kyne at 11:42 am, Jan 24, 2020

APPROVED

Montgomery County  
Historic Preservation Commission

*Sandra Heiler*

Andersen  
EXCLUSIVE  
FEATURE

ENGINEERED WITH

# FIBREX®

MATERIAL

### SMART MATERIALS

Fibrex® material is twice as strong as vinyl, so weather-tight seals stay weather-tight.

### COLOR CHOICE

Our unique process fuses color to Fibrex® material for long-lasting beauty as well as offering dark exterior colors not available on most other replacement windows.

### EXCEPTIONAL COMFORT

Fibrex® material blocks thermal transfer nearly 700 times better than aluminum to help reduce heating and cooling bills.

### EXCEPTIONAL DURABILITY

Fibrex® material retains its stability and rigidity in all climates.

	Fibrex®	Aluminum	Vinyl	Wood
Insulating Properties	✓		✓	✓
Low Maintenance	✓	✓	✓	
Resistance to Decay/Corrosion	✓		✓	
Structural Rigidity	✓	✓		✓
Durability	✓	✓		✓
Color/Finish Choices	✓			✓
Maximum Glass Area	✓	✓		varies
Dark Color Performance	✓	✓		✓

	Fibrex®	Aluminum	Vinyl	Wood
Insulating Properties	✓		✓	✓
Low Maintenance	✓	✓	✓	
Resistance to Decay/Corrosion	✓		✓	
Structural Rigidity	✓	✓		✓
Durability	✓	✓		✓
Color/Finish Choices	✓			✓
Maximum Glass Area	✓	✓		varies
Dark Color Performance	✓	✓		✓

# Profiles

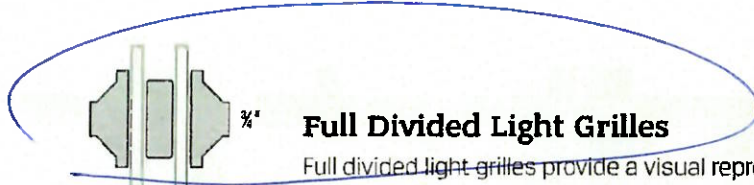
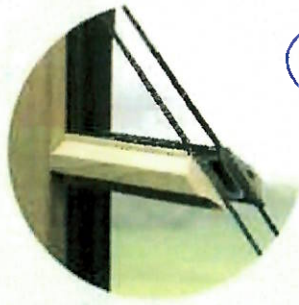

## Full Divided Light Grilles

Full divided light grilles provide a visual representation of true divided glass. The option consists of a permanently applied exterior Fibrex® material grille, an aluminum spacer between the glass, and a removable or permanently applied interior grille. Available in two widths and an array of colors.



PERMANENT

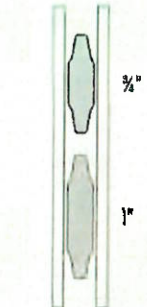

## Grilles Between-the-Glass

Aluminum grilles are permanently installed between the panes during manufacturing, providing the beauty of grilles with the quick cleaning of a smooth glass surface. Available in two widths and an array of colors.



REMOVABLE

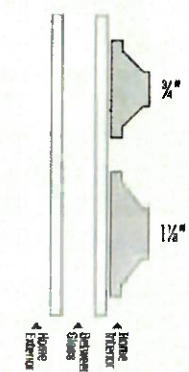

## Interior Wood Grilles

Made of hardwood, these grilles snap into clips on the interior of the sash and can be easily removed to make glass cleaning a breeze. Available in two widths.

Exterior  
Spacer  
Interior  
Grilles

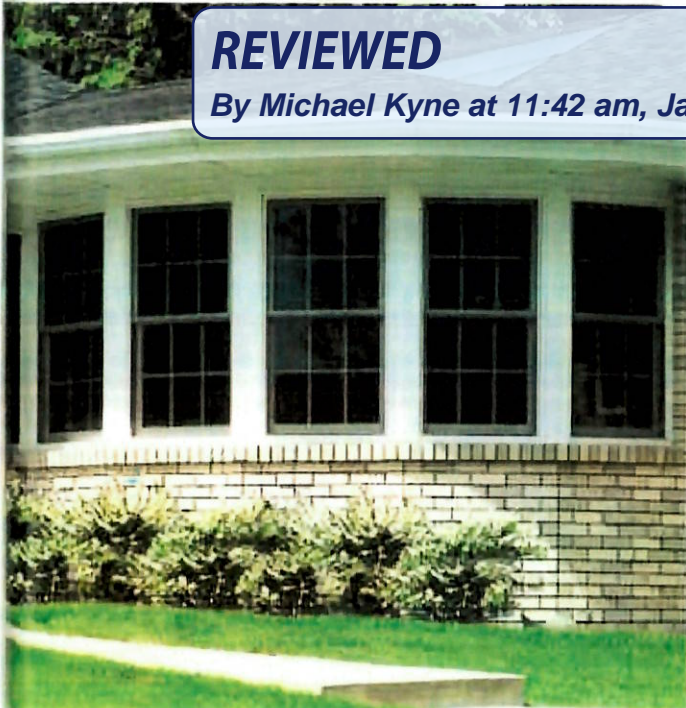

**REVIEWED**  
By Michael Kyne at 11:42 am, Jan 24, 2020



APPROVED  
Montgomery County  
Historic Preservation Commission  
*Sandra L. Skiler*

Casement Window / White Interior / Prairie Grilles



Double-Hung Window / Black Exterior / Custom Grilles

**CLEAR OPENING AND CLEAR GLASS DIMENSIONS, cont.**

DOUBLE-HUNG WINDOW

FLAT SILL INSERT

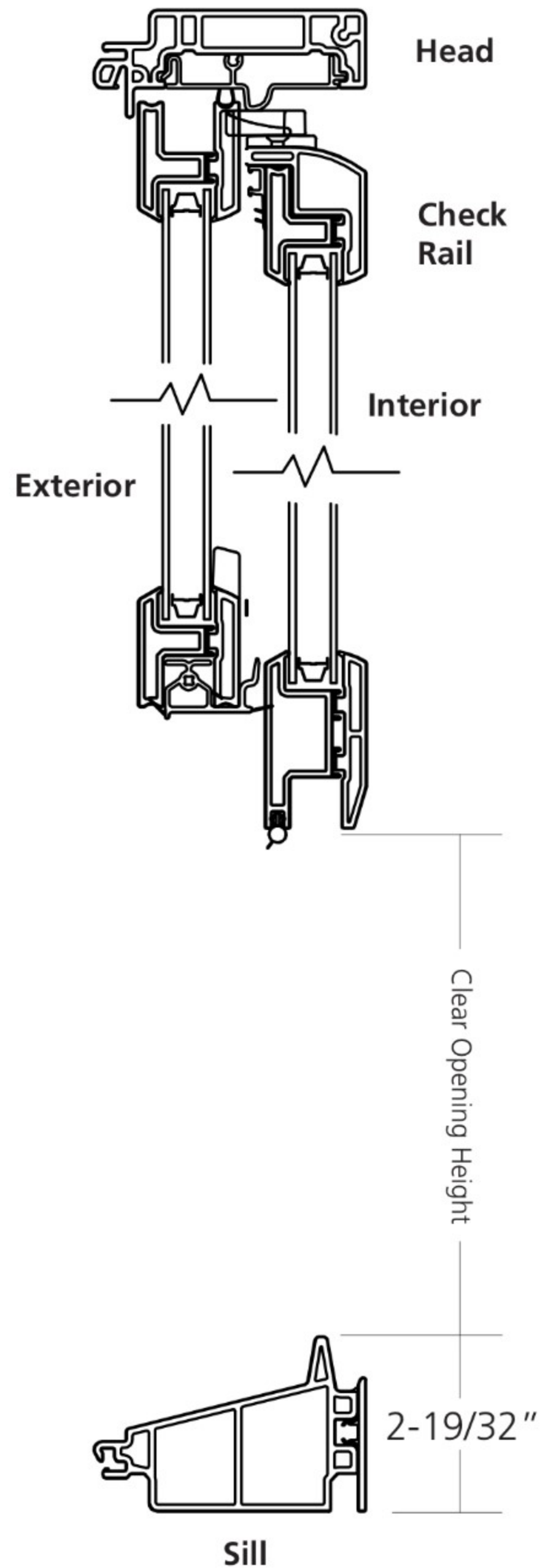
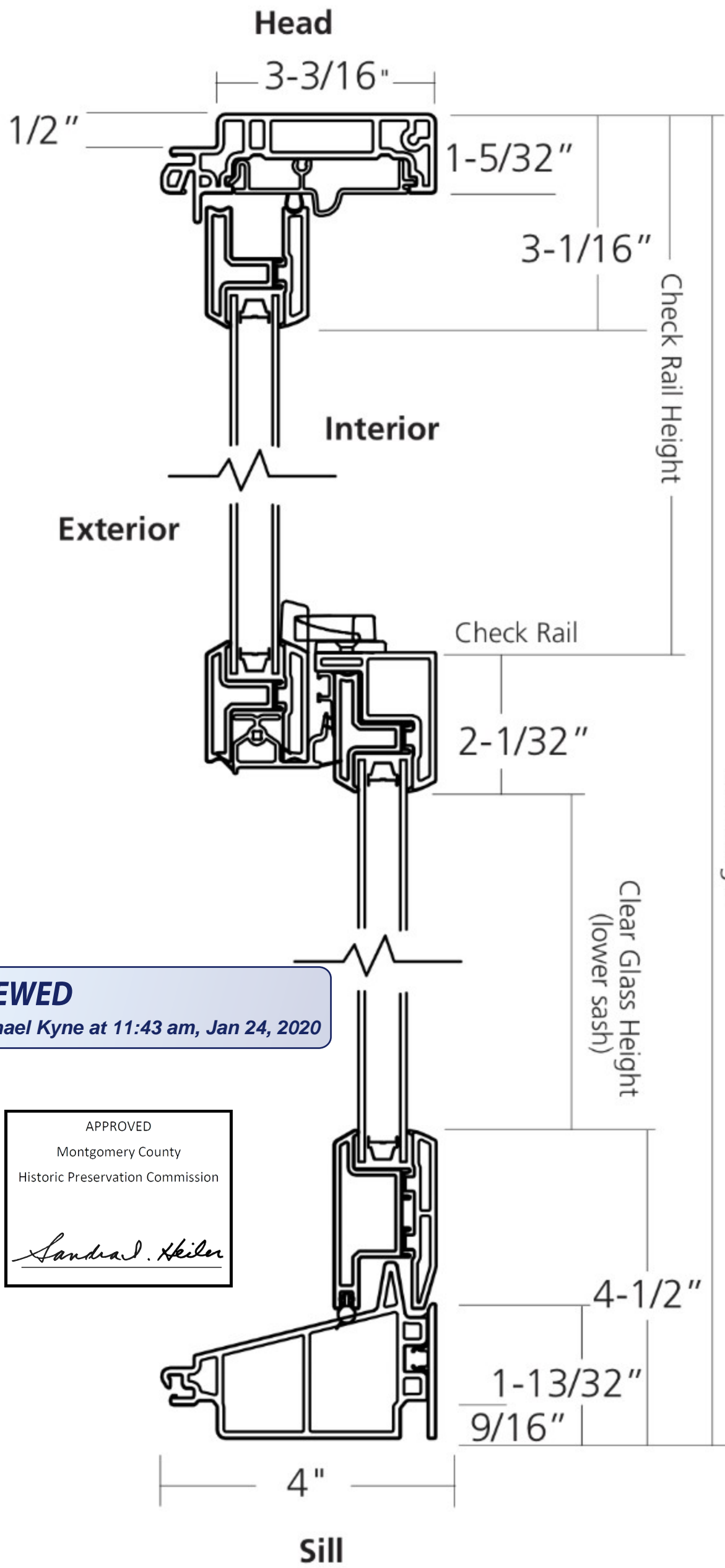

**REVIEWED**  
By Michael Kyne at 11:43 am, Jan 24, 2020

APPROVED  
Montgomery County  
Historic Preservation Commission  
*Sandra S. Heiler*



Window profiles shown for measurement purposes.

