



HISTORIC PRESERVATION COMMISSION

Marc Elrich
County Executive

Sandra I. Heiler
Chairman

Date: December 8, 2020

MEMORANDUM

TO: Mitra Pedoeem
Department of Permitting Services

FROM: Michael Kyne
Historic Preservation Section
Maryland-National Capital Park & Planning Commission

SUBJECT: Historic Area Work Permit #933277: New fence

The Montgomery County Historic Preservation Commission (HPC) has reviewed the attached application for a Historic Area Work Permit (HAWP). This application was **Approved** at the December 2, 2020 HPC meeting.

The HPC staff has reviewed and stamped the attached construction drawings.

THE BUILDING PERMIT FOR THIS PROJECT SHALL BE ISSUED CONDITIONAL UPON ADHERENCE TO THE ABOVE APPROVED HAWP CONDITIONS AND MAY REQUIRE APPROVAL BY DPS OR ANOTHER LOCAL OFFICE BEFORE WORK CAN BEGIN.

Applicant: Alex Kinnier (Jeff Rogers, Agent)
Address: 7815 Overhill Road, Bethesda

This HAWP approval is subject to the general condition that the applicant will obtain all other applicable Montgomery County or local government agency permits. After the issuance of these permits, the applicant must contact this Historic Preservation Office if any changes to the approved plan are made. Once work is complete the applicant will contact Michael Kyne at 301.563.3403 or michael.kyne@montgomeryplanning.org to schedule a follow-up site visit.



Back property line fence

Image of fence at 7819 Overhill Rd. Back property fence at 7815 Overhill will be identical to what is shown and installed as a continuous line extending from this fence at 7819 Overhill.

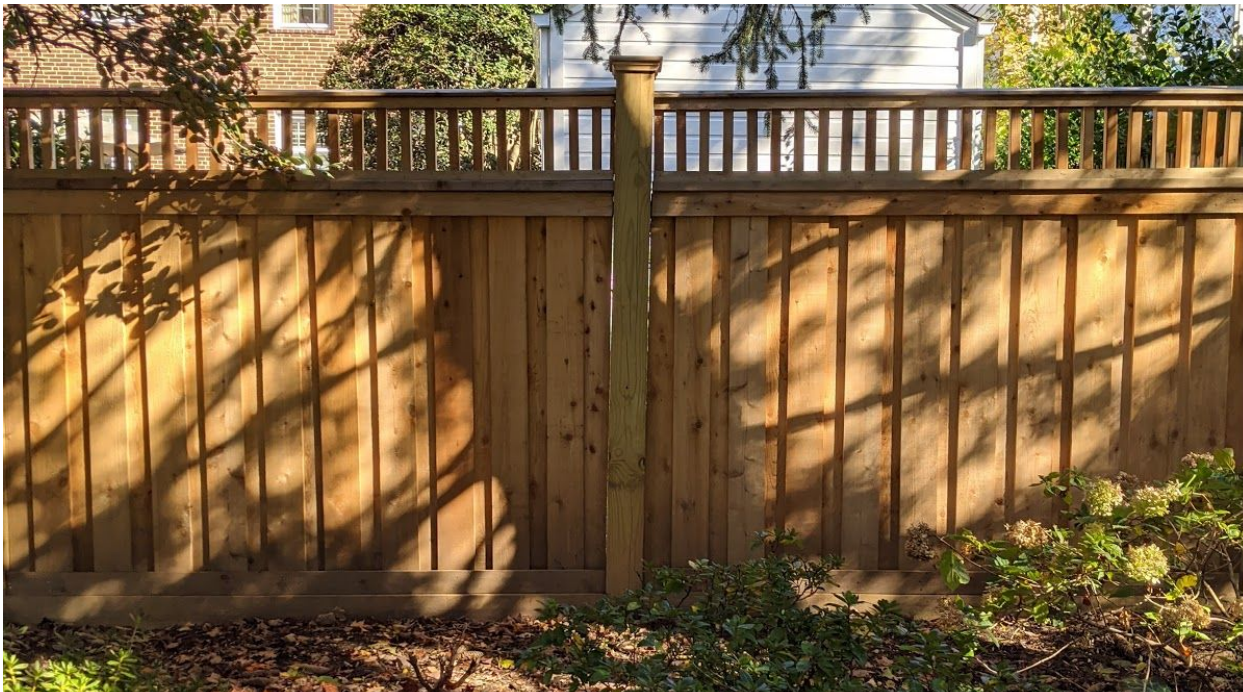

Material specification: cedar

REVIEWED

By Michael Kyne at 10:13 am, Dec 08, 2020

Replace 7815 & 7819 Overhill back yard dividing fence &

Replace connecting fence between 7815 and 7805 Overhill

APPROVED
Montgomery County
Historic Preservation Commission
Sandra J. Heiler

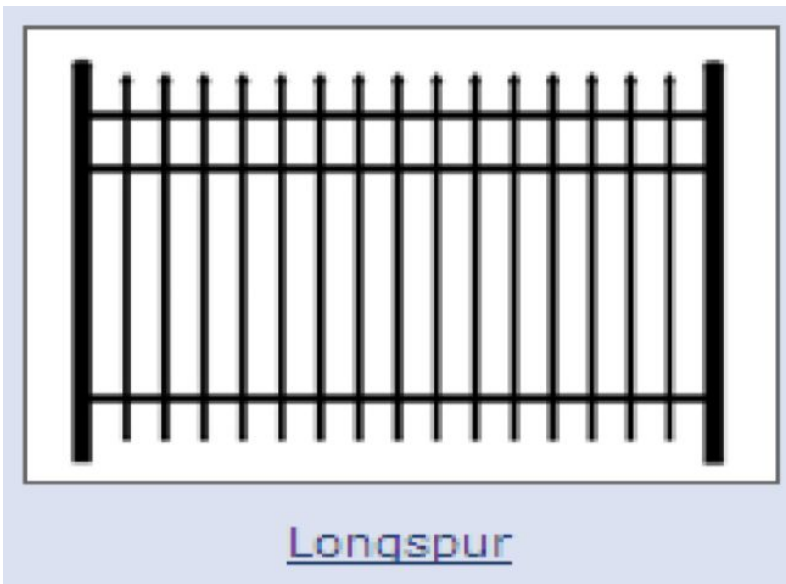

Material specification: black commercial grade aluminum

Tree survey

One non-canopy contributing 6" in diameter (measurd at 5' height) tree will be removed along the 92' back fence line.

Site Plan / Plans

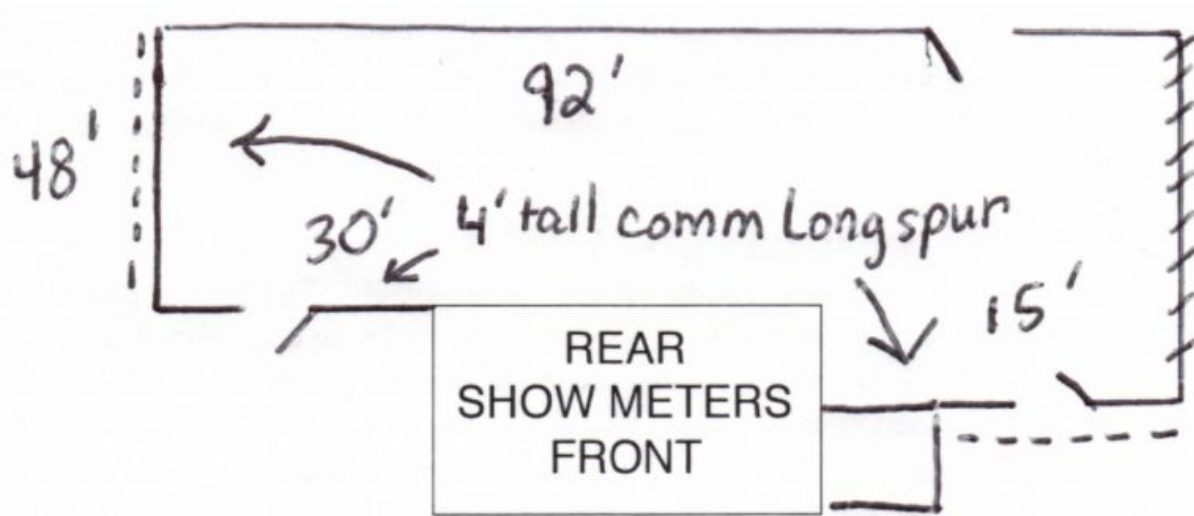

REVIEWED

By Michael Kyne at 10:13 am, Dec 08, 2020

APPROVED

Montgomery County
Historic Preservation Commission

Sandra L. Skiler