



HISTORIC PRESERVATION COMMISSION

Marc Elrich
County Executive

Robert K. Sutton
Chairman

Date: April 20, 2023

MEMORANDUM

TO: Ehsan Motazedi, Acting DPS Director & Deputy Director Department of Permitting Services

FROM: Dan Bruechert
Historic Preservation Section
Maryland-National Capital Park & Planning Commission

SUBJECT: Historic Area Work Permit #1023948 - Window Replacement

The Montgomery County Historic Preservation Commission (HPC) has reviewed the attached application for a Historic Area Work Permit (HAWP). This application was **Approved** At the April 12 2023 HPC meeting.

The HPC staff has reviewed and stamped the attached construction drawings.

THE BUILDING PERMIT FOR THIS PROJECT SHALL BE ISSUED CONDITIONAL UPON ADHERENCE TO THE ABOVE APPROVED HAWP CONDITIONS AND MAY REQUIRE APPROVAL BY DPS OR ANOTHER LOCAL OFFICE BEFORE WORK CAN BEGIN.

Applicant: Raphael Lewis
Address: 7014 Poplar Ave., Takoma Park

This HAWP approval is subject to the general condition that the applicant will obtain all other applicable Montgomery County or local government agency permits. After the issuance of these permits, the applicant must contact this Historic Preservation Office if any changes to the approved plan are made. Once work is complete the applicant will contact Dan Bruechert at 301.563.3400 or dan.bruechert@montgomeryplanning.org to schedule a follow-up site visit.



PRODUCT DETAILS

Casement Single Units

Base Frame

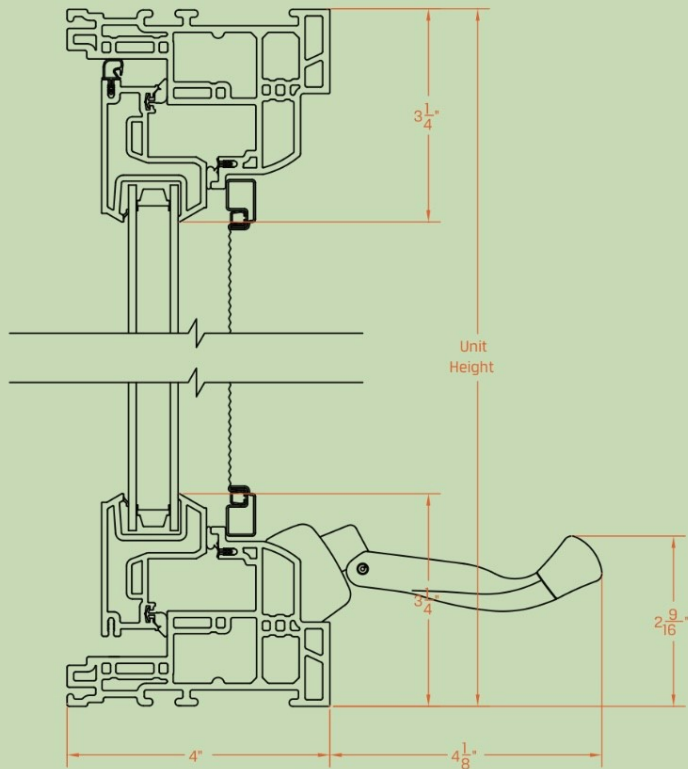

Extension Jamb (EJ) Frame

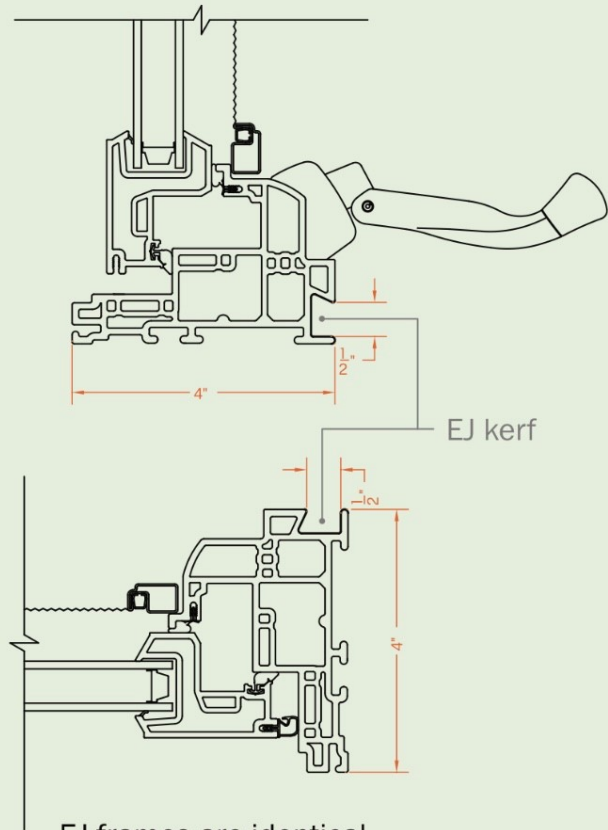

EJ frames are identical to Base frames with the exception of the EJ kerf.

Base Frame - Single Unit

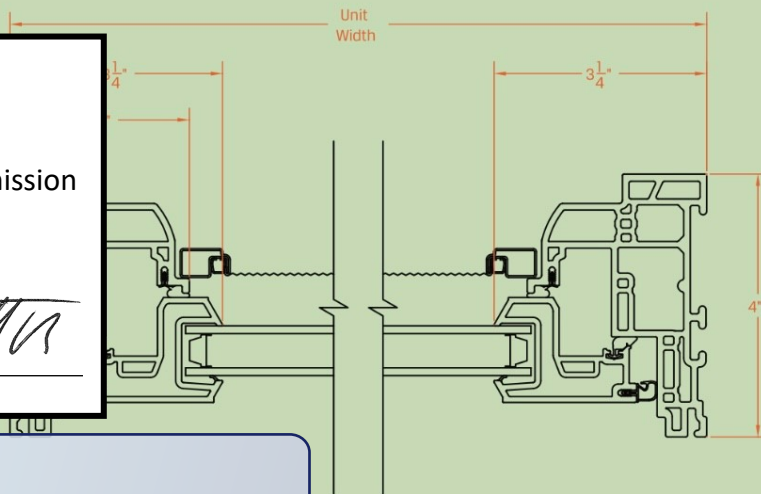

APPROVED

Montgomery County
Historic Preservation Commission

REVIEWED

By Dan.Bruechert at 12:09 pm, Apr 20, 2023

PRODUCT DETAILS

DG Double-Hung Base Frame

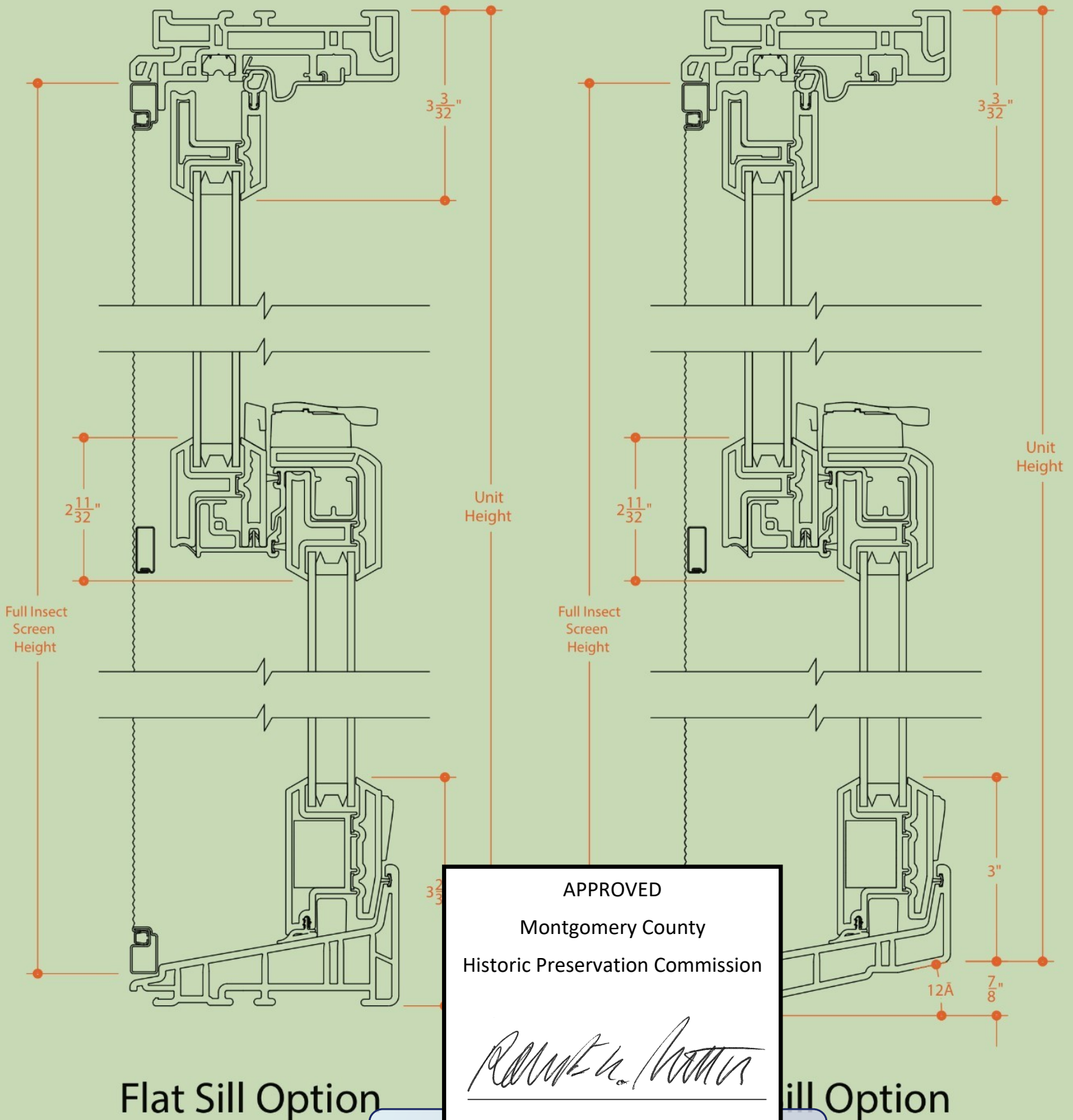

APPROVED
Montgomery County
Historic Preservation Commission

Ronald H. [Signature]

REVIEWED

By Dan.Bruechert at 12:09 pm, Apr 20, 2023

What are Renewal by Andersen® windows made of?

All of our windows are made of Fibrex® material, a revolutionary composite made from reclaimed wood fiber blended with a polymer. This gives our windows the strength and durability of wood and the low-maintenance features of vinyl, while greatly limiting thermal transmittance that can be found in other window materials such as metal.

Unlike many other window materials, Fibrex composite material won't flake, rust, blister, peel, crack, pit, or corrode.¹ It is also two times stronger than vinyl and resists warping and bowing. Never worry about scraping or painting your windows again.

ENGINEERED WITH
FIBREX[®]
MATERIAL



APPROVED
Montgomery County
Historic Preservation Commission

Ronald H. Adams

REVIEWED
By Dan.Bruechert at 12:09 pm, Apr 20, 2023

Smart Materials

Fibrex material is twice as strong as vinyl, so weathertight seals stay weathertight.

Color Choice

Our unique process fuses color to Fibrex material for long-lasting beauty. And it offers dark exterior colors not available on most other replacement windows.

Exceptional Comfort

Fibrex material blocks thermal transfer nearly 700 times better than aluminum to help reduce heating and cooling bills.

Outstanding Durability

Fibrex material retains its stability and rigidity in all climates.¹

	FIBREX MATERIAL	VINYL	ALUMINUM	WOOD
Insulating Properties	✓	✓		✓
Low Maintenance	✓	✓	✓	
Resistance to Decay/Corrosion	✓	✓		
Structural Rigidity	✓		✓	✓
Durability	✓		✓	✓
Color Choices	✓			✓
Dark Color Performance	✓		11	✓



108
107

109

101a/b

113 114 115

110

REVIEWED
By Dan.Bruechert at 12:10 pm, Apr 20, 2023

APPROVED
Montgomery County
Historic Preservation Commission

Front Elevation, Left



REVIEWED
By Dan.Bruechert at 12:10 pm, Apr 20, 2023

APPROVED
Montgomery County
Historic Preservation Commission
Ronald W. ...

Front Elevation, Right

PRODUCT DETAILS

Gliding Window AS and SA Universal Frame - Base

APPROVED
Montgomery County
Historic Preservation Commission

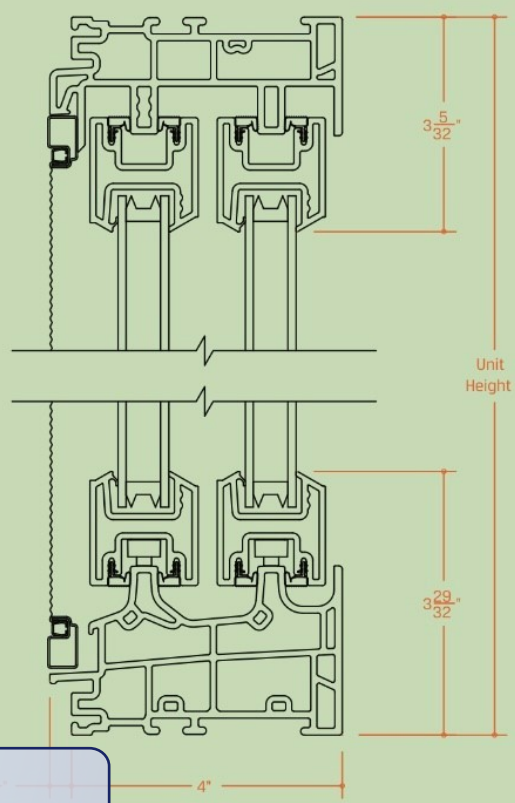

REVIEWED
By Dan.Bruechert at 12:10 pm, Apr 20, 2023

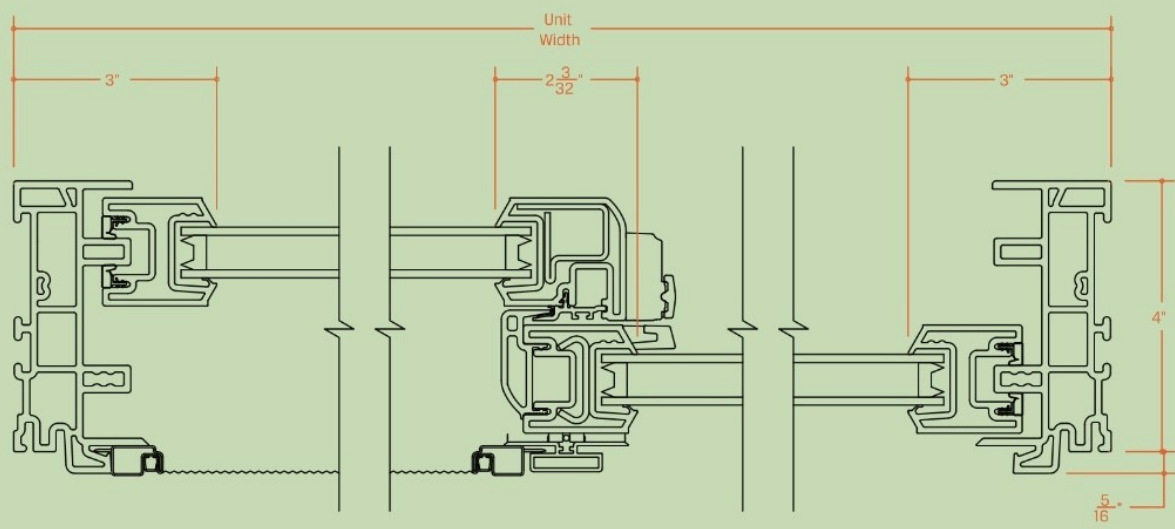

APPROVED

Montgomery County

Historic Preservation Commission



REVIEWED

By Dan.Bruechert at 12:10 pm, Apr 20, 2023

104

105

106

Rear Elevation



proposed

Zachary Rickards (571)405-0415

Susan Salek

7014 Poplar Ave
Tacoma Park , MD 20912
(202)794-0322

rSuite Capital Price 1.26.2023

ID#	ROOM	SIZE	DETAILS
-----	------	------	---------

Misc: Misc, CapRegion Job, Permit Fee (All non- COFA), A delay in installation can be expected and is dependent on the local jurisdiction.

101a Living

32 W
45 H

Window: Double-Hung (DG) , 1:1, Flat Sill, Insert Frame, Traditional Checkrail, Exterior White, Interior White
Performance Calculator: PG Rating: 40 | DP Rating: +40 / - 40
Glass: All Sash: High Performance SmartSun Glass, No Pattern
Hardware: White
Screen: Fiberglass , Half Screen
Grille Style: Grilles Between Glass (GBG)
Grille Pattern: Sash 1: Colonial 3w x 1h , Sash 2: No Grille
Misc: Trim- Omit Interior , New Interior Trim not needed/desired.

101b Living

32 W
45 H

Window: Double-Hung (DG) , 1:1, Flat Sill, Insert Frame, Traditional Checkrail, Exterior White, Interior White
Performance Calculator: PG Rating: 40 | DP Rating: +40 / - 40
Glass: All Sash: High Performance SmartSun Glass, No Pattern
Hardware: White
Screen: Fiberglass , Half Screen
Grille Style: Grilles Between Glass (GBG)
Grille Pattern: Sash 1: Colonial 3w x 1h , Sash 2: No Grille
Misc: Trim- Omit Interior , New Interior Trim not needed/desired.

102 Living

32 W
45 H

Window: Double-Hung (DG) , 1:1, Flat Sill, Insert Frame, Traditional Checkrail, Exterior White, Interior White
Performance Calculator: PG Rating: 40 | DP Rating: +40 / - 40
Glass: All Sash: High Performance SmartSun Glass, No Pattern
Hardware: White
Screen: Fiberglass , Half Screen
Grille Style: Grilles Between Glass (GBG)
Grille Pattern: Sash 1: Colonial 3w x 1h , Sash 2: No Grille
Misc: Trim- Omit Interior , New Interior Trim not needed/desired.

APPROVED

Montgomery County
Historic Preservation Commission



REVIEWED
By Dan.Bruechert at 12:10 pm, Apr 20, 2023

- | | | | |
|------------|----------|--------------|--|
| 103 | Bedroom | 32 W
45 H | <p>Window: Double-Hung (DG) , 1:1, Flat Sill, Insert Frame, Traditional Checkrail, Exterior White, Interior White</p> <p>Performance Calculator: PG Rating: 40 DP Rating: + 40 / - 40</p> <p>Glass: All Sash: High Performance SmartSun Glass, No Pattern</p> <p>Hardware: White</p> <p>Screen: Fiberglass , Half Screen</p> <p>Grille Style: Grilles Between Glass (GBG)</p> <p>Grille Pattern: Sash 1: Colonial 3w x 1h , Sash 2: No Grille</p> <p>Misc: Trim- Omit Interior , New Interior Trim not needed/desired.</p> |
| 104 | Bedroom | 32 W
45 H | <p>Window: Double-Hung (DG) , 1:1, Flat Sill, Insert Frame, Traditional Checkrail, Exterior White, Interior White</p> <p>Performance Calculator: PG Rating: 40 DP Rating: + 40 / - 40</p> <p>Glass: All Sash: High Performance SmartSun Glass, No Pattern</p> <p>Hardware: White</p> <p>Screen: Fiberglass , Half Screen</p> <p>Grille Style: Grilles Between Glass (GBG)</p> <p>Grille Pattern: Sash 1: Colonial 3w x 1h , Sash 2: No Grille</p> <p>Misc: Trim- Omit Interior , New Interior Trim not needed/desired.</p> |
| 105 | Bathroom | 24 W
37 H | <p>Window: Casement , Single, Right, Base Frame, Exterior White, Interior White</p> <p>Performance Calculator: PG Rating: 40 DP Rating: + 40 / - 40</p> <p>Glass: All Sash: High Performance SmartSun Glass, Obscure , Tempered Glass</p> <p>Hardware: White</p> <p>Screen: Fiberglass , Full Screen</p> <p>Grille Style: No Grille</p> <p>Misc: Trim- Omit Interior , New Interior Trim not needed/desired.</p> |
| 106 | office | 32 W
45 H | <p>Window: Double-Hung (DG) , 1:1, Flat Sill, Insert Frame, Traditional Checkrail, Exterior White, Interior White</p> <p>Performance Calculator: PG Rating: 40 DP Rating: + 40 / - 40</p> <p>Glass: All Sash: High Performance SmartSun Glass, No Pattern</p> <p>Hardware: White</p> <p>Screen: Fiberglass , Half Screen</p> <p>Grille Style: Grilles Between Glass (GBG)</p> <p>Grille Pattern: Sash 1: Colonial 3w x 1h , Sash 2: No Grille</p> <p>Misc: Trim- Omit Interior , New Interior Trim not needed/desired.</p> |
| 107 | office | 32 W
45 H | <p>Window: Double-Hung (DG) , 1:1, Flat Sill, Insert Frame, Traditional Checkrail, Exterior White, Interior White</p> <p>Performance Calculator: PG Rating: 40 DP Rating: + 40 / - 40</p> <p>Glass: All Sash: High Performance SmartSun Glass, No Pattern</p> <p>Hardware: White</p> <p>Screen: Fiberglass , Half Screen</p> <p>Grille Style: Grilles Between Glass (GBG)</p> <p>Grille Pattern: Sash 1: Colonial 3w x 1h , Sash 2: No Grille</p> <p>Misc: Trim- Omit Interior , New Interior Trim not needed/desired.</p> |

APPROVED

Montgomery County
Historic Preservation Commission



REVIEWED
By Dan.Bruechert at 12:10 pm, Apr 20, 2023

108 Kitchen 24 W
37 H

Window: Double-Hung (DG) , 1:1, Flat Sill, Insert Frame, Traditional Checkrail, Exterior White, Interior White
Performance Calculator: PG Rating: 40 | DP Rating: + 40 / - 40
Glass: All Sash: High Performance SmartSun Glass, No Pattern
Hardware: White
Screen: Fiberglass , Half Screen
Grille Style: Grilles Between Glass (GBG)
Grille Pattern: Sash 1: Colonial 2w x 1h , Sash 2: No Grille
Misc: Trim- Omit Interior , New Interior Trim not needed/desired.

109 Kitchen 32 W
37 H

Window: Casement , Single, Left, Base Frame, Exterior White, Interior White
Performance Calculator: PG Rating: 40 | DP Rating: + 40 / - 40
Glass: All Sash: High Performance SmartSun Glass, No Pattern
Hardware: White
Screen: Fiberglass , Full Screen
Grille Style: Grilles Between Glass (GBG)
Grille Pattern: All Sash: Farmhouse 3w x 1h
Misc: Trim- Omit Interior , New Interior Trim not needed/desired.

110 basement bed 36 W
24 H

Window: Gliding , Double, 1:1, Active / Passive, Base Frame, Exterior White, Interior White
Performance Calculator: PG Rating: 40 | DP Rating: + 40 / - 40
Glass: All Sash: High Performance SmartSun Glass, No Pattern
Hardware: White
Screen: Fiberglass , Half Screen
Grille Style: No Grille
Misc: Trim- Omit Interior , New Interior Trim not needed/desired.

111 basement bed 36 W
24 H

Window: Gliding , Double, 1:1, Active / Passive, Base Frame, Exterior White, Interior White
Performance Calculator: PG Rating: 40 | DP Rating: + 40 / - 40
Glass: All Sash: High Performance SmartSun Glass, No Pattern
Hardware: White
Screen: Fiberglass , Half Screen
Grille Style: No Grille
Misc: Trim- Omit Interior , New Interior Trim not needed/desired.

112 basement 36 W
24 H

Window: Gliding , Double, 1:1, Active / Passive, Base Frame, Exterior White, Interior White
Performance Calculator: PG Rating: 40 | DP Rating: + 40 / - 40
Glass: All Sash: High Performance SmartSun Glass, No Pattern
Hardware: White
Screen: Fiberglass , Half Screen
Grille Style: No Grille
Misc: Trim- Omit Interior , New Interior Trim not needed/desired.

113 basement bath 36 W
24 H

Window: Gliding , Double, 1:1, Active / Passive, Base Frame, Exterior White, Interior White
Performance Calculator: PG Rating: 40 | DP Rating: + 40 / - 40
Glass: All Sash: High Performance SmartSun Glass, No Pattern
Hardware: White
Screen: Fiberglass , Half Screen
Grille Style: No Grille
Misc: Trim- Omit Interior , New Interior Trim not needed/desired.

APPROVED
Montgomery County
Historic Preservation Commission

REVIEWED
By Dan.Bruechert at 12:10 pm, Apr 20, 2023

114 Laundry 36 W
24 H

Window: Gliding , Double, 1:1, Active / Passive, Base Frame, Exterior White, Interior White
Performance Calculator: PG Rating: 40 | DP Rating: + 40 / - 40
Glass: All Sash: High Performance SmartSun Glass, No Pattern
Hardware: White
Screen: Fiberglass , Half Screen
Grille Style: No Grille
Misc: Trim- Omit Interior , New Interior Trim not needed/desired.

115 Laundry 36 W
24 H

Window: Gliding , Double, 1:1, Active / Passive, Base Frame, Exterior White, Interior White
Performance Calculator: PG Rating: 40 | DP Rating: + 40 / - 40
Glass: All Sash: High Performance SmartSun Glass, No Pattern
Hardware: White
Screen: Fiberglass , Half Screen
Grille Style: No Grille
Misc: Trim- Omit Interior , New Interior Trim not needed/desired.

WINDOWS: 16 PATIO DOORS: 0 ENTRY DOORS: 0 SPECIALTY: 0 MISC: 1

UPDATED: 03/08/23

APPROVED
Montgomery County
Historic Preservation Commission



REVIEWED
By Dan.Bruechert at 12:10 pm, Apr 20, 2023