



HISTORIC PRESERVATION COMMISSION

Marc Elrich
County Executive

Robert Sutton
Chairman

Date: April 27, 2023

MEMORANDUM

TO: Rabbiah Sabbakhan
Department of Permitting Services

FROM: Michael Kyne
Historic Preservation Section
Maryland-National Capital Park & Planning Commission

SUBJECT: Historic Area Work Permit #1025691: Construction of two outbuildings

The Montgomery County Historic Preservation Commission (HPC) has reviewed the attached application for a Historic Area Work Permit (HAWP). This application was **Approved** at the April 26, 2023 HPC meeting.

The HPC staff has reviewed and stamped the attached construction drawings.

THE BUILDING PERMIT FOR THIS PROJECT SHALL BE ISSUED CONDITIONAL UPON ADHERENCE TO THE ABOVE APPROVED HAWP CONDITIONS AND MAY REQUIRE APPROVAL BY DPS OR ANOTHER LOCAL OFFICE BEFORE WORK CAN BEGIN.

Applicant: Alexis Leonard (Agent)
Address: 17320 Moore Road, Boyds

This HAWP approval is subject to the general condition that the applicant will obtain all other applicable Montgomery County or local government agency permits. After the issuance of these permits, the applicant must contact this Historic Preservation Office if any changes to the approved plan are made. Once work is complete the applicant will contact Michael Kyne at 301.563.3403 or Michael.Kyne@montgomeryplanning.org to schedule a follow-up site visit.





MONTGOMERY PARKS

The Maryland-National Capital Park and Planning Commission
2425 Reedie Drive | Wheaton, MD 20902
MontgomeryParks.org

REVIEWED

By Michael Kyne at 2:05 pm, Apr 27, 2023

November 18, 2022

Alexis Leonard
Executive Director
Great and Small
17320 Moore Rd,
Boyd's, MD 20841



Re: Concept Review for
Great and Small Run in
Sheds

Project Type:
Installation of run in
sheds

Concept Approval Letter for Project Proposed on Parkland

Dear Alexis Leonard,

Based on a review led by the Park Planning and Stewardship Division staff, the concept plan for the run in sheds proposed at Rickman Horse Farm is acceptable. The concept plan proposes to meet the Mission, Vision, and Values of the Montgomery County Department of Parks and that, with avoidance, minimization and/or mitigation the impacts to natural, cultural, and/or recreational amenities within the Park are acceptable.

The following items will need to be addressed during the detailed Park Construction Permit application stage:

1. Great and Small to verify whether or not anchors will be required for the structure by manufacturer (Parks may still require anchor points)
2. A lease amendment may be required to codify Great and Small's maintenance responsibility for the structures
3. Parks Archaeology staff will perform shovel test pit investigations at the proposed shed location closest to the Joseph White House prior to installation
4. A Historic Area Work Permit is required before work may begin
5. A preconstruction meeting will be held before sheds are placed

This list may not be all-inclusive and may change when more detailed project information is provided.

This letter must be included in the Park Construction Permit application with the first Technical Review submittal (i.e. 60% design). Any divergence from the information provided in this concept may constitute grounds to rescind or amend concept approval and to reevaluate the project for additional or amended conditions and requirements.

MONTGOMERY PARKS

The Maryland-National Capital Park and Planning Commission
2425 Reedie Drive | Wheaton, MD 20902
MontgomeryParks.org

The Park Development Division issues permits approving work to be done on properties owned and/or managed by the M-NCPPC and on properties dedicated to M-NCPPC. A Park Construction Permit must be issued prior to the commencement of any work on property owned, managed or being dedicated to the M-NCPPC.

If you have any questions, please feel free to call Jacqueline Hoban at 240.772.6623 or email Jacqueline.Hoban@montgomeryparks.org.

Sincerely,
Jacqueline Hoban

CC:
Michael Zelaski
Jay Childs
Joshua Arnett
Cassandra Michaud
Timothy Crump
Scott Whipple

REVIEWED

By Michael Kyne at 2:05 pm, Apr 27, 2023

APPROVED

Montgomery County

Historic Preservation Commission





REVIEWED
By Michael Kyne at 2:05 pm, Apr 27, 2023

APPROVED
Montgomery County
Historic Preservation Commission

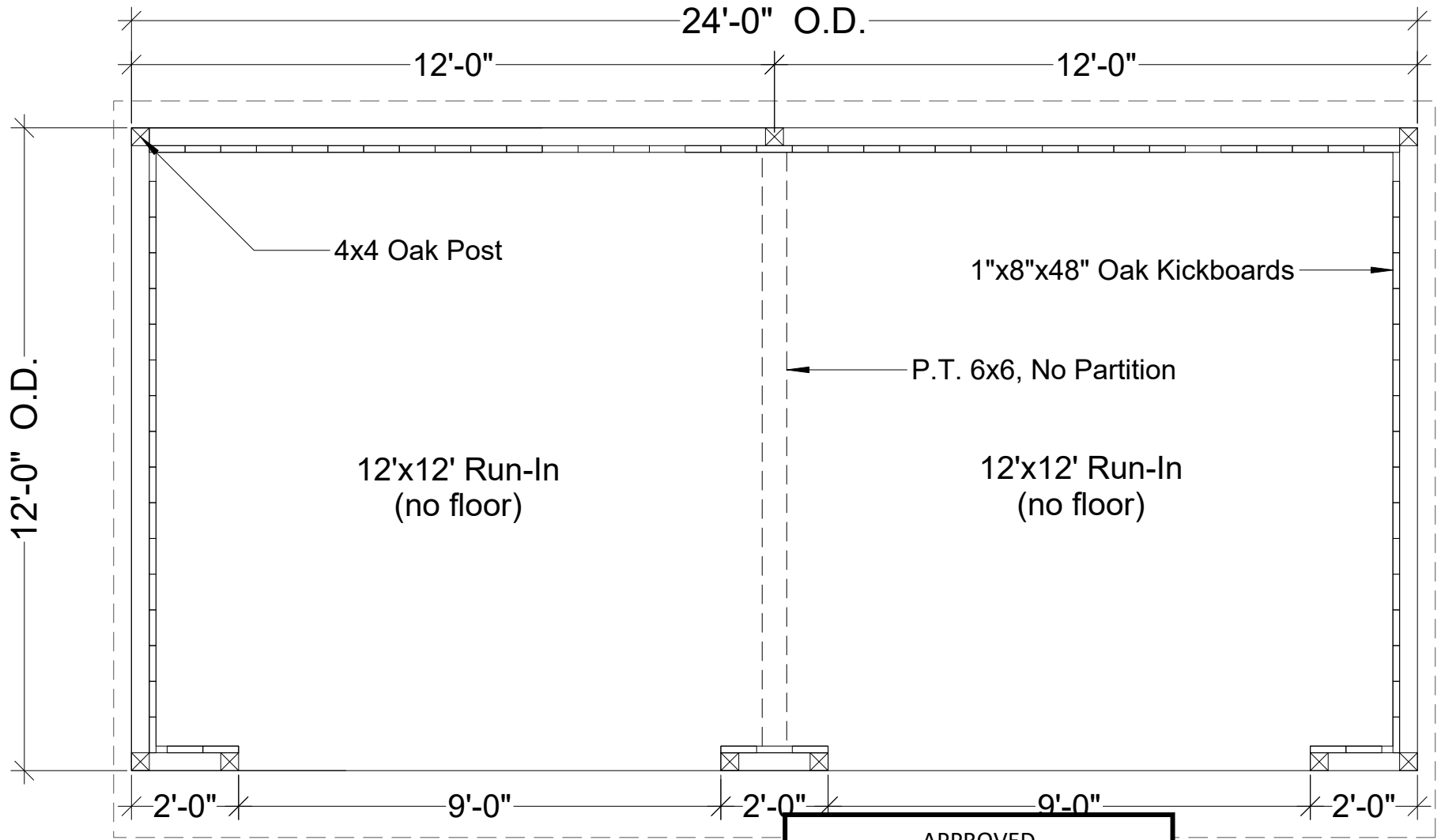



REVIEWED
 By Michael Kyne at 2:07 pm, Apr 27, 2023

APPROVED
 Montgomery County
 Historic Preservation Commission

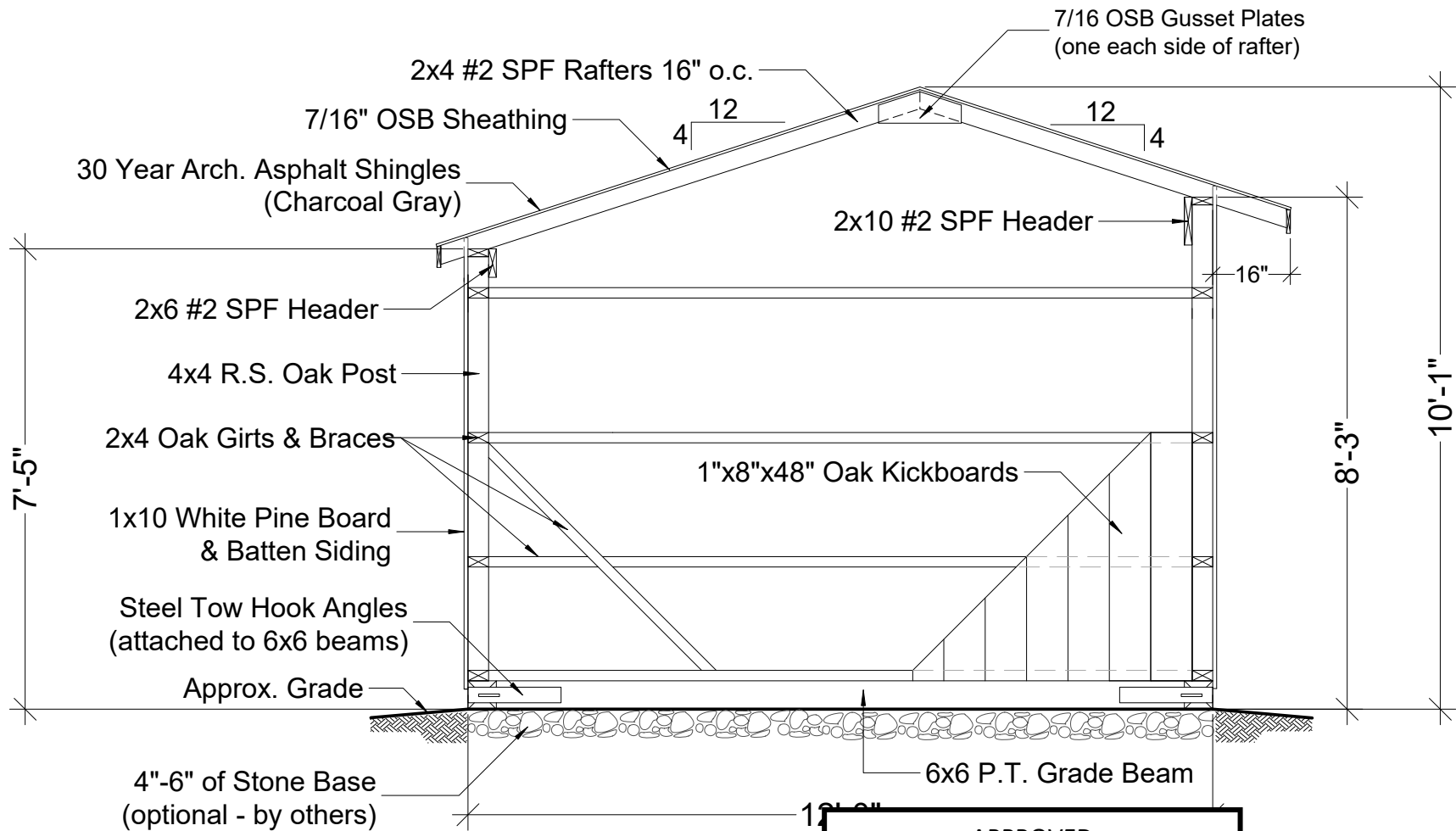

	1. EXTERIOR WALLS TO BE LINED ON INSIDE w/ 1 x 8 OAK VERTICAL KICKBOARDS UP TO 4'-0"	DRAWING PREPARED BY Great and 17320 Moor Boyds, MD	12'x24' RUN IN SHED FLOOR PLAN	SCALE: _____ SHEET: A.2
--	---	---	-----------------------------------	-------------------------



REVIEWED
 By Michael Kyne at 2:07 pm, Apr 27, 2023

APPROVED
 Montgomery County
 Historic Preservation Commission



DESIGN LOADS (ASCE 7-16)
 (RISK CATEGORY-I / AGRICULTURAL BUILDING)

WIND LOAD - 105 MPH

SNOW LOAD:
 LIVE LOAD - 35 PSF PLUS DRIFT
 DEAD LOAD - ROOF WITH SHINGLES 10 PSF

NOTES:
 When placing shed on stone pad, make the pad at least 12"-24" larger on each side of shed.

DRAWING
 Great
 17320
 Boyds, MD 20811

12'x24' RUN IN SHED

GABLE DETAILS

SCALE _____ SHEET **A.1**

2022 Great and Small Map



Legend

Blue = Property boundary

Red = Lease boundary

Green = Field boundary

Teal = Stream

REVIEWED

By Michael Kyne at 2:07 pm, Apr 27, 2023

APPROVED

Montgomery County

Historic Preservation Commission



DEPARTMENT OF PERMITTING SERVICES

Marc Elrich
County Executive

Rabbiah Sabbakhan
Director

HISTORIC AREA WORK PERMIT APPLICATION

Application Date: 3/23/2023

Application No: 1025691
AP Type: HISTORIC
Customer No: 1434423

Comments

Great and Small, which has a long term lease with MCP-PC , requests the opportunity to place run in sheds in our horse pastures for shelter for the horses in our therapeutic riding program. Project has preliminarily cleared by MCP-PC and Historical Preservation.

Affidavit Acknowledgement

The Contractor is the Primary applicant authorized by the property owner
This application does not violate any covenants and deed restrictions

Primary Applicant Information

Address 17320 MOORE RD
BOYDS, MD 20841
Othercontact Great and Small (Primary)

Historic Area Work Permit Details

Work Type ADD
Scope of Work Great and Small requests placing two, 12x24 pre-fabricated wood sheds in two horse pastures on the Rickman Farm Horse Park.

REVIEWED
By Michael Kyne at 2:07 pm, Apr 27, 2023

APPROVED
Montgomery County
Historic Preservation Commission

Adjacent and Confronting Properties:

Boys, MD 20841

P.O. Box 86 Poolesville, MD 20837

17410 Moore Road

19001 Bucklodge Road

19301 Bucklodge Road

REVIEWED

By Michael Kyne at 2:08 pm, Apr 27, 2023

APPROVED

Montgomery County

Historic Preservation Commission



Robert H. Patton