



HISTORIC PRESERVATION COMMISSION

Marc Elrich
County Executive

Sandra I. Heiler
Chairman

Date: June 25, 2020

MEMORANDUM

TO: Mitra Pedoeem
Department of Permitting Services

FROM: Dan Bruechert
Historic Preservation Section
Maryland-National Capital Park & Planning Commission

SUBJECT: Historic Area Work Permit #915253 - Sign Replacement

The Montgomery County Historic Preservation Commission (HPC) has reviewed the attached application for a Historic Area Work Permit (HAWP). This application was **approved** at the June 24, 2020 HPC meeting.

The HPC staff has reviewed and stamped the attached construction drawings.

THE BUILDING PERMIT FOR THIS PROJECT SHALL BE ISSUED CONDITIONAL UPON ADHERENCE TO THE ABOVE APPROVED HAWP CONDITIONS AND MAY REQUIRE APPROVAL BY DPS OR ANOTHER LOCAL OFFICE BEFORE WORK CAN BEGIN.

Applicant: Warner Memorial Presbyterian Church
Address: 10123 Connecticut Ave., Kensington

This HAWP approval is subject to the general condition that the applicant will obtain all other applicable Montgomery County or local government agency permits. After the issuance of these permits, the applicant must contact this Historic Preservation Office if any changes to the approved plan are made. Once work is complete the applicant will contact Dan Bruechert at 301.563.3400 or dan.bruechert@montgomeryplanning.org to schedule a follow-up site visit.



Warner Memorial Presbyterian Church
Drawing for Replacement Sign
3901 PROSPECT ST. Kensington, MD

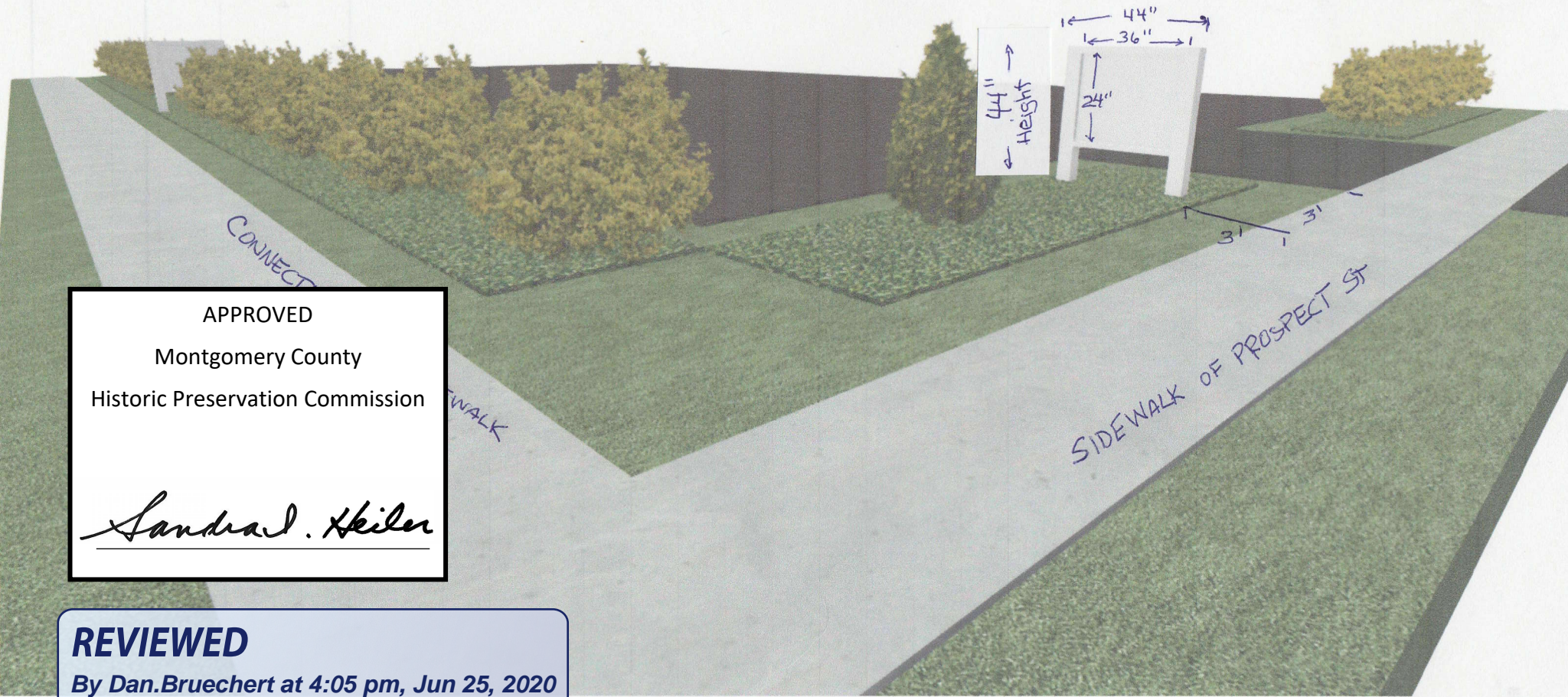

APPROVED

Montgomery County
Historic Preservation Commission

Sandra L. Heiler

REVIEWED

By Dan.Bruechert at 4:05 pm, Jun 25, 2020

April 10, 2020

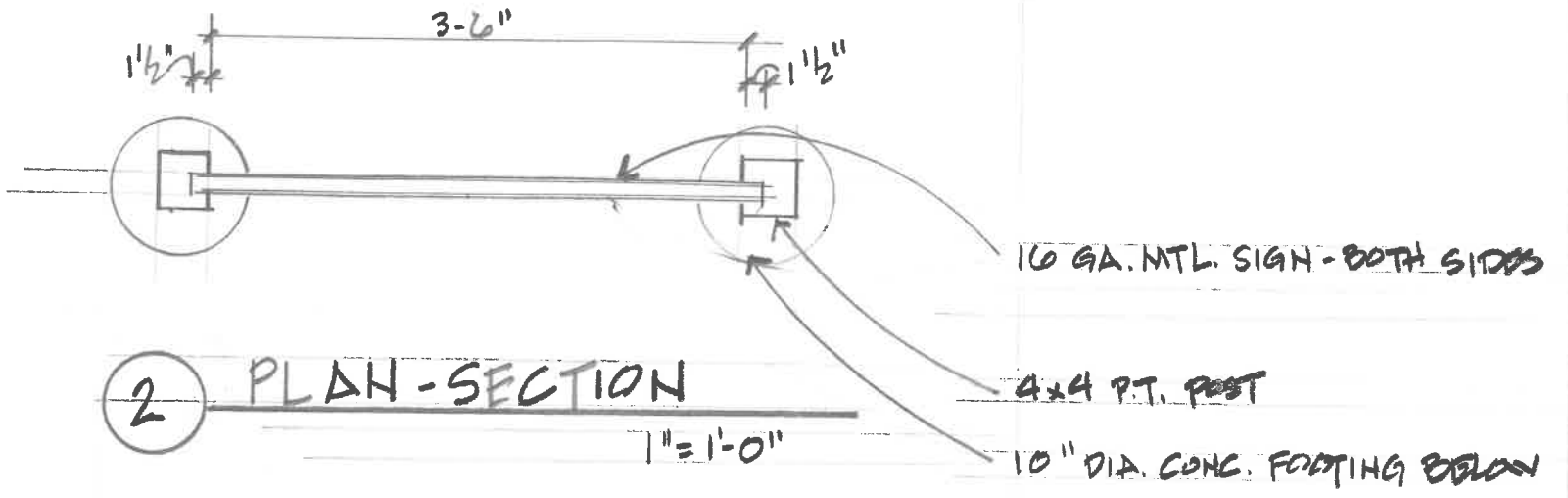

2 PLAN-SECTION
1" = 1'-0"

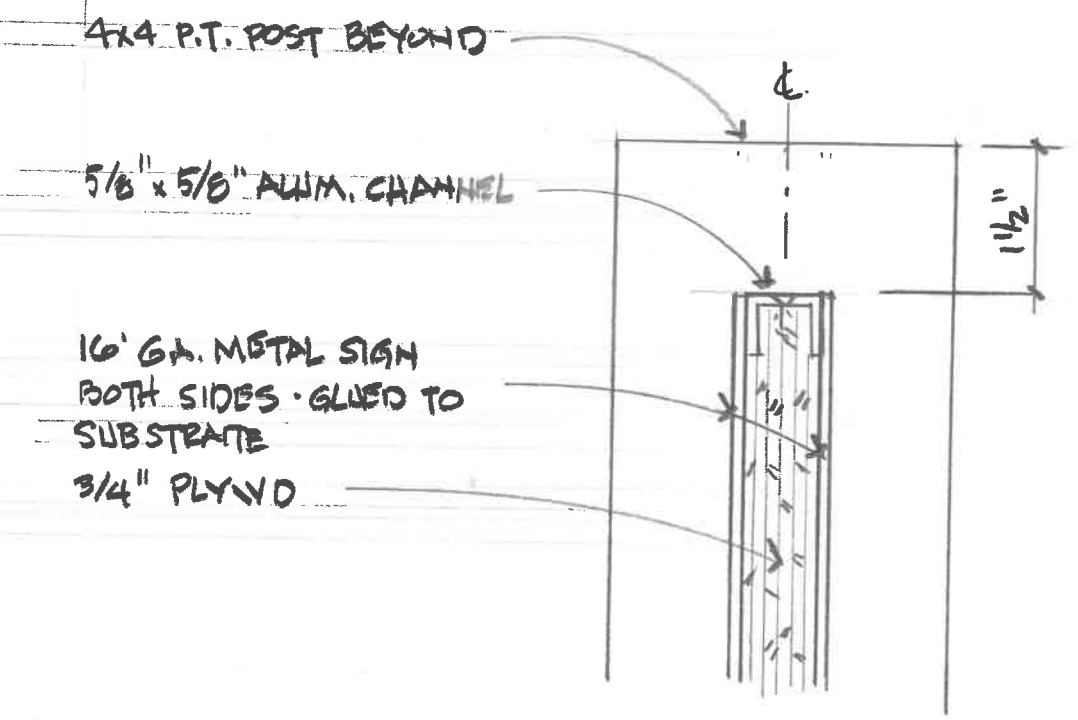

3 SECTION
HALF

APPROVED
Montgomery County
Historic Preservation Commission
Sandra L. Heiler

REVIEWED
By Dan.Bruechert at 4:05 pm, Jun 25, 2020

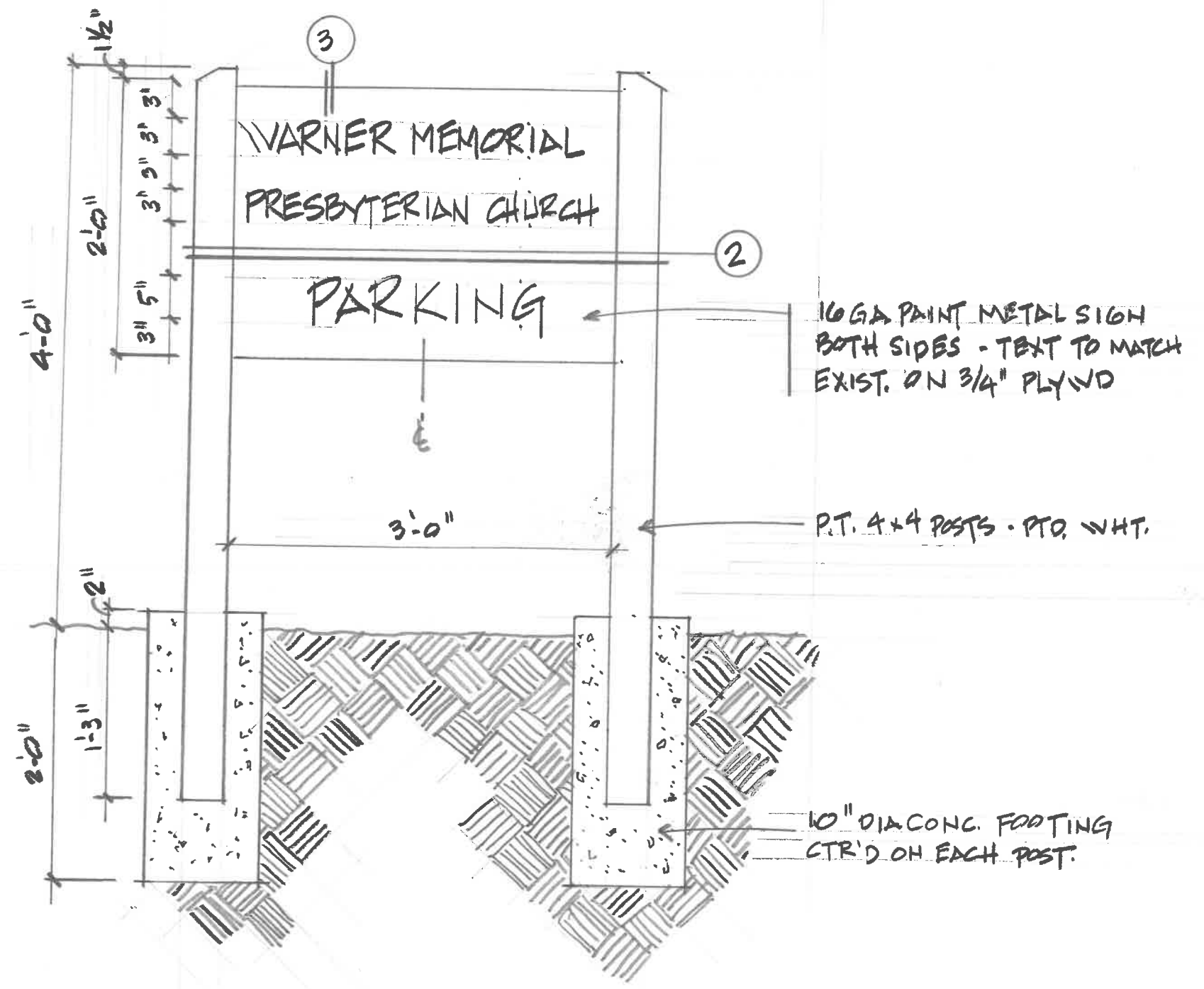

1 ELEVATION
1" = 1'-0"

WARNER MEMORIAL PRESBYTERIAN CHURCH

PARKING LOT SIGN

17 MAY 2020