



HISTORIC PRESERVATION COMMISSION

Marc Elrich
County Executive

Robert Sutton
Chairman

Date: November 13 2023

MEMORANDUM

TO: Rabbiah Sabbakhan
Department of Permitting Services

FROM: Dan Bruechert
Historic Preservation Section
Maryland-National Capital Park & Planning Commission

SUBJECT: Historic Area Work Permit #1033248 - Siding, Window, and Door Replacement

The Montgomery County Historic Preservation Commission (HPC) has reviewed the attached application for a Historic Area Work Permit (HAWP). This application was **Approved** at the June 28, 2023 HPC meeting.

The HPC staff has reviewed and stamped the attached construction drawings.

THE BUILDING PERMIT FOR THIS PROJECT SHALL BE ISSUED CONDITIONAL UPON ADHERENCE TO THE ABOVE APPROVED HAWP CONDITIONS AND MAY REQUIRE APPROVAL BY DPS OR ANOTHER LOCAL OFFICE BEFORE WORK CAN BEGIN.

Applicant: Stephen Kelleher
Address: 8829 Hawkins Ln., Chevy Chase

This HAWP approval is subject to the general condition that the applicant will obtain all other applicable Montgomery County or local government agency permits. After the issuance of these permits, the applicant must contact this Historic Preservation Office if any changes to the approved plan are made. Once work is complete the applicant will contact Dan Bruechert at 301.563.3400 or dan.bruechert@montgomeryplanning.org to schedule a follow-up site visit.



APPROVED
Montgomery County
Historic Preservation Commission



REVIEWED
By Dan.Bruechert at 3:36 pm, Nov 13, 2023

Hardie lap siding

Replace window/door

Hardie trim

*Hardie soffit, Lomar fascia/rak
alum gutter w/ leaf relief
on fascia*

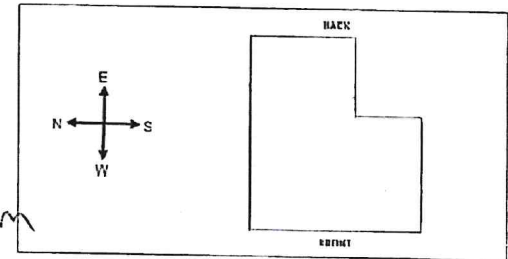

SKB

 Hardie lap siding

 Hardie trim

 Hardie soffit,
Loman fascia, rake
alum gutter w/
leaf relief on
fascia

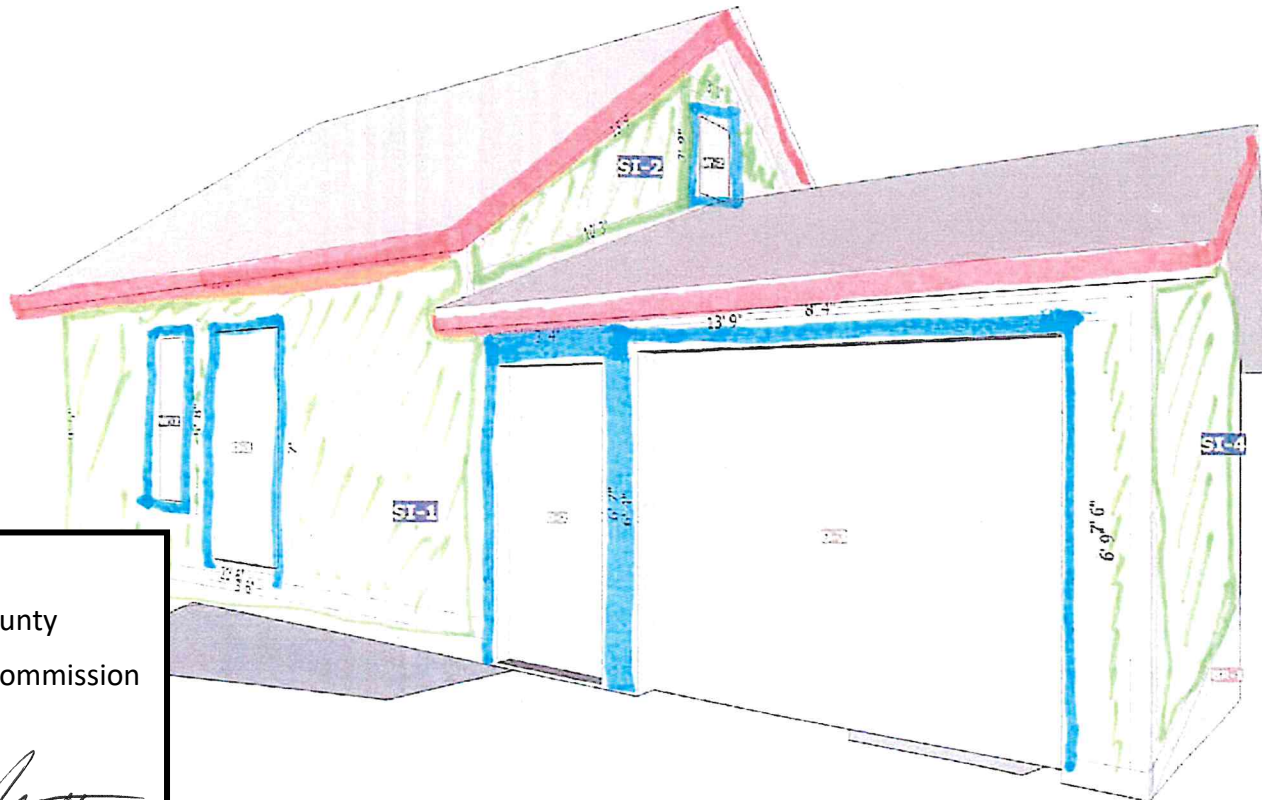
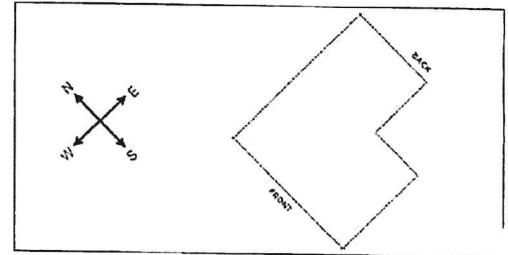

APPROVED
Montgomery County
Historic Preservation Commission

Robert A. [Signature]

REVIEWED
By Dan.Bruechert at 3:37 pm, Nov 13, 2023

AKC

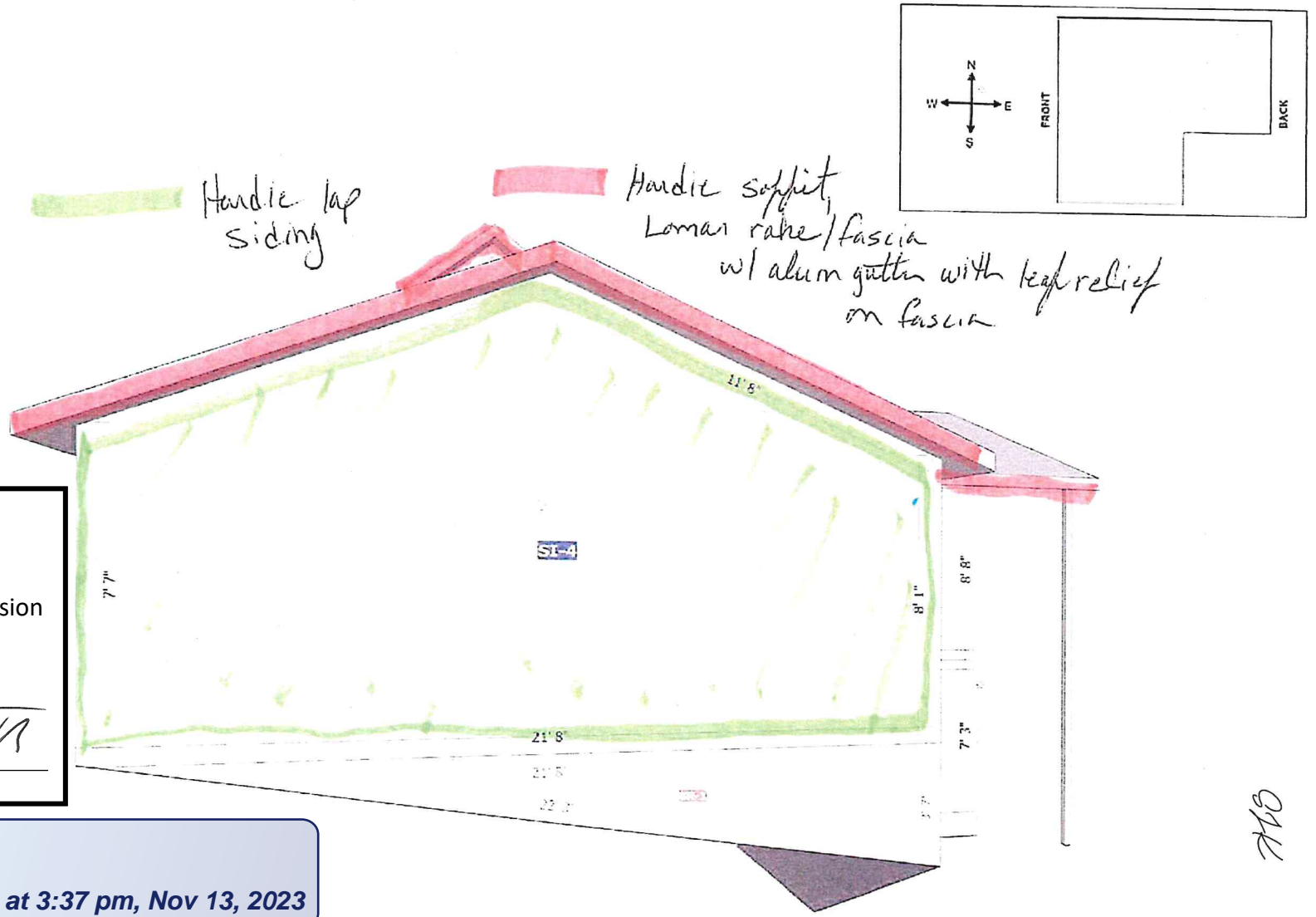

APPROVED
Montgomery County
Historic Preservation Commission

[Signature]

REVIEWED
By Dan.Bruechert at 3:37 pm, Nov 13, 2023

© 2021 HOVER Inc. All rights reserved. This document and the images, measurement data, format and contents are the exclusive property of HOVER. HOVER is the registered trademark of Hover Inc. All other brands, products and company names mentioned herein may be trademarks or registered trademarks of their respective holders.

Use of this document is subject to HOVER's Terms of Use and is provided "as is." HOVER makes no guarantees, representations or warranties of any kind, express or implied, arising by law or otherwise relating to this document or its contents or use, including but not limited to, quality, accuracy, completeness, reliability, or fitness for a particular purpose.

PROPERTY ID: 4251037
STEVE KELLEHER
03 MAY 2021 19 Page 10

AKB

- Replace window
- Hardie Board or batten siding
- Hardie lap siding
- Hardie trim
- Hardie soffit w/ Lomar fascia/rake and aluminum with leaf relief on fascia

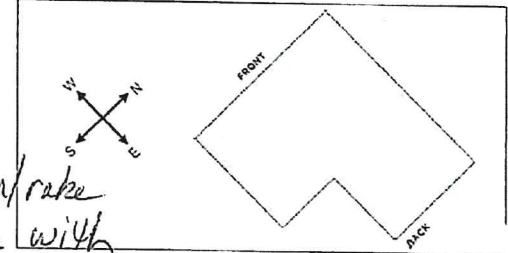



APPROVED
Montgomery County
Historic Preservation Commission

Ronald A. Potter

REVIEWED
By Dan.Bruechert at 3:37 pm, Nov 13, 2023

AKB

 Hardie lap siding

 Hardie Board + Batten

 Hardie soffit, Lomar fascia/rake and alum gutter w/ leaf relief on fascia

 Replace window/door

 Hardie trim

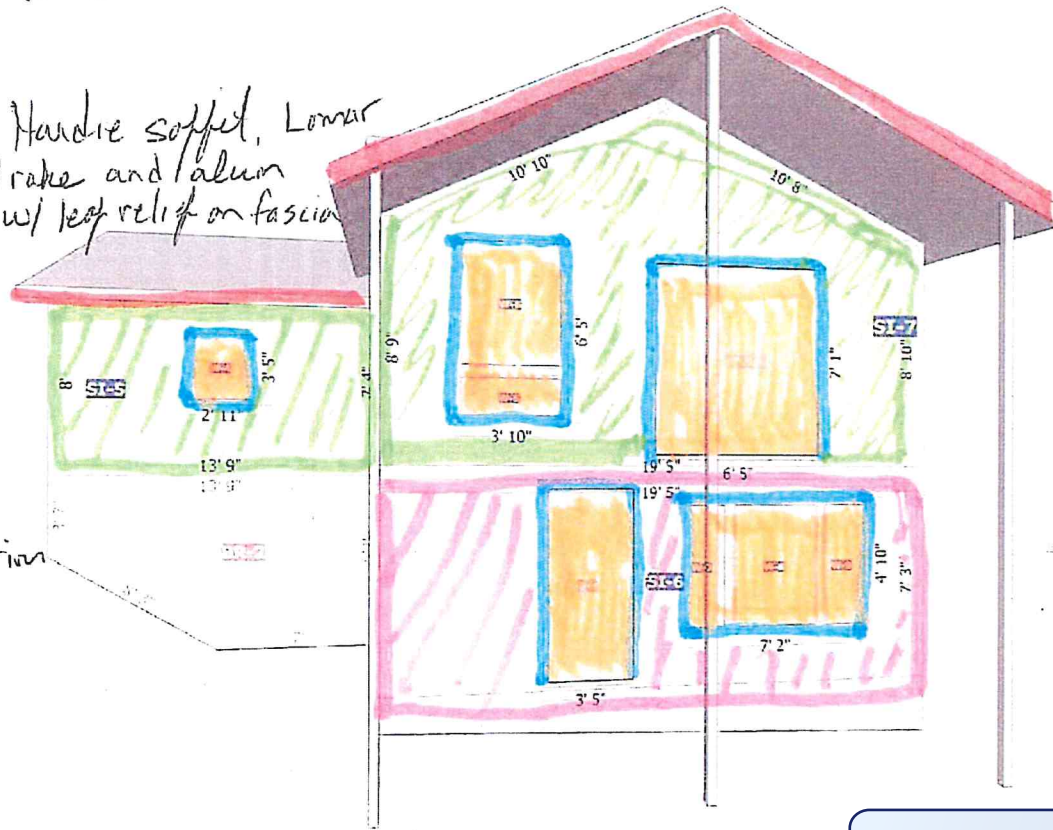
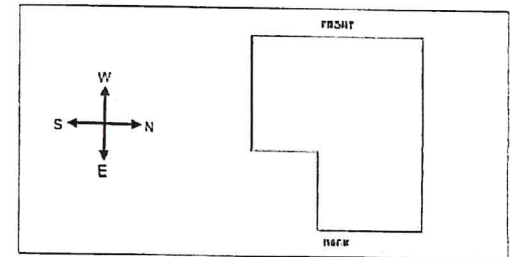

APPROVED

Montgomery County
Historic Preservation Commission

Ronald A. Porter

REVIEWED

By Dan.Bruechert at 3:37 pm, Nov 13, 2023

Kelleher Elevate

Quote #: 6DWAX6R

A Proposal for Window and Door Products prepared for:

Shipping Address:

ALCO PRODUCTS COMPANY INC-CIR
4921 WYACONDA ROAD
NORTH BETHESDA, MD 20852



PRODUCTS COMPANY, INC.

MICHELLE REYNOLDS
ALCO PRODUCTS COMPANY INC-CIR
4921 WYACONDA ROAD
NORTH BETHESDA, MD 20852
Phone: (202) 816-2504

Email: mreynolds@alcoproductsinc.com

This report was generated on 11/6/2023 7:18:08 AM using the Marvin Order Management System, version 0004.05.00 (Current). Price in USD. Unit availability and price are subject to change. Dealer terms and conditions may apply.

Featuring products from:



APPROVED

Montgomery County
Historic Preservation Commission

A handwritten signature in black ink, appearing to read "Randy A. [unclear]", is written over a horizontal line.

REVIEWED

By Dan.Bruechert at 3:32 pm, Nov 13, 2023

APPROVED
 Montgomery County
 Historic Preservation Commission



REVIEWED
 By Dan.Bruechert at 3:32 pm, Nov 13, 2023

UNIT SUMMARY

The following is a summary of the quotes.
 Additional charges apply.

For this project. For additional unit details, please see Line Item
 Detail pricing is per unit.

NUMBER OF LINES: 14 TOTAL UNIT QTY: 14

| LINE | MARK UNIT | PRODUCT LINE | ITEM | QTY |
|------|------------------------|--------------|---|-----|
| 1 | Front Room Casement W1 | Elevate | Casement RO 20" X 60 1/2" Entered as FS 19" X 60" | 1 |
| 2 | Living Room W2 | Elevate | Elevate Assembly RO 47" X 77 1/2" Entered as Size by Units | 1 |
| 3 | Polygon Window W3 | Elevate | Direct Glaze Polygon P4 RO 46" X 78" Entered as RO 46" X 78" | 1 |
| 5 | Eating area W4 | Elevate | Direct Glaze Rectangle RO 40" X 75" Entered as RO 40" X 75" | 1 |
| 6 | Eating Area W5 | Elevate | Awning RO 41" X 26 1/2" Entered as FS 40" X 26" | 1 |
| 7 | Sliding Door W6 | Elevate | Sliding Patio Door RO 72" X 80 1/2" Entered as FS 71" X 80" | 1 |
| 8 | Rear of home W7 | Elevate | Elevate Assembly RO 44" X 69 1/2" Entered as Size by Units | 1 |
| 9 | Basement W8 | Elevate | Glider CN 3624 RO 36 1/2" X 24 1/4" Entered as CN 3624 | 1 |
| 10 | Basement W9 | Elevate | Double Hung RO 37" X 48 1/2" Entered as FS 36" X 48" | 1 |
| 11 | Basement Casement W10 | Elevate | Casement RO 20" X 48 1/2" Entered as FS 19" X 48" | 1 |
| 12 | Basement W11 | Elevate | Glider Triple Sash RO 83" X 53 1/2" Entered as FS 82" X 53" | 1 |
| 13 | Basement W12 | Elevate | Awning RO 31" X 20 1/2" Entered as FS 30" X 20" | 1 |
| 14 | Garage W13 | Elevate | Double Hung RO 37" X 39 1/2" | 1 |

| | | | | |
|----|-----------------------------|---------|---|---|
| 15 | 2nd floor W14 - build up | Elevate | Entered as FS 36" X 39" Double Hung RO 31" X 39 1/2" Entered as FS 30" X 39" | 1 |
|----|-----------------------------|---------|---|---|



REVIEWED
By Dan.Bruechert at 3:32 pm, Nov 13, 2023

LINE ITEM QUOTES

The following is a schedule of the windows and doors for this project. For additional unit details, please see Line Item Quotes. Additional charges, tax or Terms and Conditions may apply. Detail pricing is per unit.

| | | | | |
|---------|-----------------------------------|--|--|--|
| Line #1 | Mark Unit: Front Room Casement W1 | | | |
| Qty: 1 | | | | |

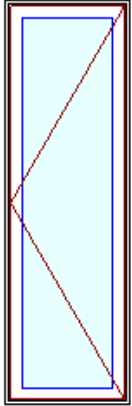

As Viewed From The Exterior

Entered As: FS
 FS 19" X 60"
 RO 20" X 60 1/2"
Egress Information
 Width: 10 15/64" Height: 55 19/32"
 Net Clear Opening: 3.95 SqFt

Stone White Exterior
 White Interior
 Elevate Casement - Left Hand
 Frame Size 19" X 60"
 Rough Opening 20" X 60 1/2"
 Stone White Exterior
 White Interior
 IG - 1 Lite
 Low E2 w/Argon
 Stainless Perimeter Bar
 White Folding Handle
 Interior Aluminum Screen
 Bright View Mesh
 White Surround
 4 9/16" Jamb
 Nailing Fin

Materials: Qty 24: WM327 (2-1/4" Clamshell) ** NON-TAXABLE ITEM

Labor: Qty 1: Full Jamb Install ** NON-TAXABLE ITEM
*****Note: Unit Availability and Price is Subject to Change**

Initials required
 Seller: _____
 Buyer: _____

| | | | | |
|---------|---------------------------|--|--|--|
| Line #2 | Mark Unit: Living Room W2 | | | |
| Qty: 1 | | | | |

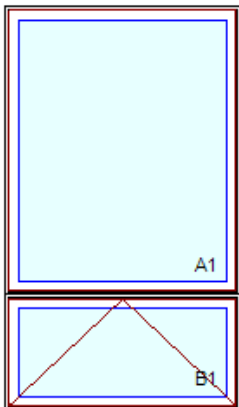

As Viewed From The Exterior

Entered As: Size by Units
 FS 46" X 77"
 RO 47" X 77 1/2"
Egress Information A1, B1
 No Egress Information available.

Stone White Exterior
 White Interior
 1W2H - Rectangle Assembly
 Assembly Rough Opening
 47" X 77 1/2"

Unit: A1
 Elevate Casement Picture
 Basic Frame 46" X 55"
 Rough Opening 47" X 55 1/2"
 Stone White Exterior
 White Interior
 IG - 1 Lite
 Low E2 w/Argon
 Stainless Perimeter Bar

Unit: B1
 Elevate Awning - Roto Operating
 Basic Frame 46" X 22"
 Rough Opening 47" X 22 1/2"
 Stone White Exterior
 White Interior
 IG - 1 Lite
 Low E2 w/Argon
 Stainless Perimeter Bar
 White Folding Handle



REVIEWED
 By Dan.Bruechert at 3:32 pm, Nov 13, 2023

Interior Aluminum Screen
 Bright View Mesh
 White Surround
 4 9/16" Jambs
 Nailing Fin

Materials: Qty 24: WM327 (2-1/4" Clamshell) ** NON-TAXABLE ITEM

Labor: Qty 1: Full Jamb Install ** NON-TAXABLE ITEM

***Note: Unit Availability and Price is Subject to Change



| | | |
|---------|------------------------------|--|
| Line #3 | Mark Unit: Polygon Window W3 | |
| Qty: 1 | | |

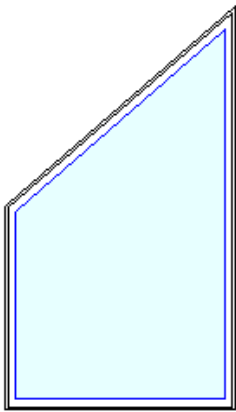

As Viewed From The Exterior

Entered As: RO
 FS 45" X 76 59/64"
 RO 46" X 78"

Egress Information

No Egress Information available.

Stone White Exterior
 White Interior
 Elevate Direct Glaze Polygon P4-5
 Rough Opening 46" X 78"
 S1 Rough Opening 39"
 IG - 1 Lite
 Low E2 w/Argon
 Stainless Perimeter Bar
 Additional Mull Info: Stand Alone
 4 9/16" Jambs
 Nailing Fin CA/AWN Frame

Materials: Qty 24: WM327 (2-1/4" Clamshell) ** NON-TAXABLE ITEM

Labor: Qty 1: Full Jamb Install ** NON-TAXABLE ITEM

***Note: Unit Availability and Price is Subject to Change

REVIEWED
 By Dan.Bruechert at 3:32 pm, Nov 13, 2023

Initials required

Seller: _____

Buyer: _____

| | | | | |
|---------|---------------------------|--|--|--|
| Line #5 | Mark Unit: Eating area W4 | | | |
| Qty: 1 | | | | |



Stone White Exterior
 White Interior
 Elevate Direct Glaze Rectangle
 Rough Opening 40" X 75"
 IG - 1 Lite
 Low E2 w/Argon
 Stainless Perimeter Bar
 Additional Mull Info: Stand Alone
 4 9/16" Jambs
 Nailing Fin CA/AWN Frame

Materials: Qty 24: WM327 (2-1/4" Clamshell) ** NON-TAXABLE ITEM

Labor: Qty 1: Full Jamb Install ** NON-TAXABLE ITEM

***Note: Unit Availability and Price is Subject to Change

Initials required

Seller: _____
 Buyer: _____

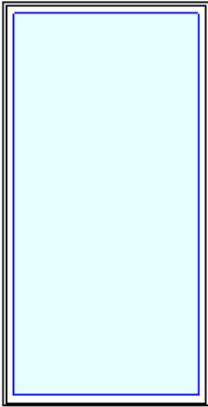

As Viewed From The Exterior

Entered As: RO
 FS 39" X 74 1/2"
 RO 40" X 75"
Egress Information
 No Egress Information available.



REVIEWED
 By Dan.Bruechert at 3:32 pm, Nov 13, 2023

| | | | | |
|---------|---------------------------|--|--|--|
| Line #6 | Mark Unit: Eating Area W5 | | | |
| Qty: 1 | | | | |

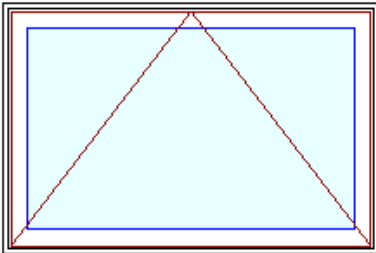

As Viewed From The Exterior

Entered As: FS
 FS 40" X 26"
 RO 41" X 26 1/2"
Egress Information
 No Egress Information available.

Stone White Exterior
 White Interior
 Elevate Awning - Roto Operating
 Frame Size 40" X 26"
 Standard CN Width 41
 Rough Opening 41" X 26 1/2"
 Stone White Exterior
 White Interior
 IG - 1 Lite
 Low E2 w/Argon
 Stainless Perimeter Bar
 White Folding Handle
 Interior Aluminum Screen
 Bright View Mesh
 White Surround
 4 9/16" Jambs
 Nailing Fin

Materials: Qty 24: WM327 (2-1/4" Clamshell) ** NON-TAXABLE ITEM

Labor: Qty 1: Full Jamb Install ** NON-TAXABLE ITEM

***Note: Unit Availability and Price is Subject to Change

Initials required

Seller: _____
 Buyer: _____

| | | | | |
|---------|----------------------------|--|--|--|
| Line #7 | Mark Unit: Sliding Door W6 | | | |
| Qty: 1 | | | | |



Stone White Exterior
 White Interior
 Elevate Sliding Patio Door OX
 Frame Size 71" X 80"
 Standard CN Width 60
 Rough Opening 72" X 80 1/2"
 Left Panel

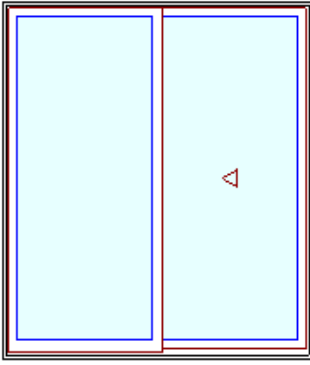

As Viewed From The Exterior

Entered As: FS
 FS 71" X 80"
 RO 72" X 80 1/2"
Egress Information
 Width: 29 17/64" Height: 75 15/64"
 Net Clear Opening: 15.29 SqFt

- Stone White Exterior
 - White Interior
 - IG - 1 Lite
 - Tempered Low E2 w/Argon
 - Stainless Perimeter Bar
 - Right Panel
 - Stone White Exterior
 - White Interior
 - IG - 1 Lite
 - Tempered Low E2 w/Argon
 - Stainless Perimeter Bar
 - White Interior Weather Strip Package
 - Cambridge Handle White Exterior Primary Handle Set
 - Cambridge Handle White Interior Primary Handle Set
 - Non Keyed
 - Exterior Sliding Screen
 - Stone White Surround
 - Bright View Mesh
 - ***Screen/Combo Ship Loose
 - Bronze Ultrex Sill / Black Weather Strip
 - 4 9/16" Jambs
 - Nailing Fin
- Materials: Qty 24: WM327 (2-1/4" Clamshell) ** NON-TAXABLE ITEM
- Labor: Qty 1: Sliding Patio Door 5-6' ** NON-TAXABLE ITEM
- ***Note: Unit Availability and Price is Subject to Change**

Initials required
 Seller: _____
 Buyer: _____

Line #8
 Qty: 1

Mark Unit: Rear of home W7

REVIEWED
 By Dan.Bruechert at 3:32 pm, Nov 13, 2023

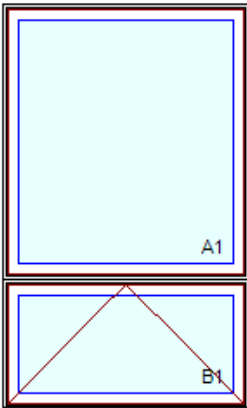

As Viewed From The Exterior

Entered As: Size by Units
 FS 43" X 69"
 RO 44" X 69 1/2"
Egress Information A1, B1
 No Egress Information available.

- Stone White Exterior
- White Interior
- 1W2H - Rectangle Assembly
- Assembly Rough Opening
- 44" X 69 1/2"
- Unit: A1
- Elevate Casement Picture
- Basic Frame 43" X 47"
- Rough Opening 44" X 47 1/2"
- Stone White Exterior
- White Interior
- IG - 1 Lite
- Low E2 w/Argon
- Stainless Perimeter Bar
- Unit: B1
- Elevate Awning - Roto Operating
- Basic Frame 43" X 22"
- Rough Opening 44" X 22 1/2"
- Stone White Exterior
- White Interior
- IG - 1 Lite
- Low E2 w/Argon
- Stainless Perimeter Bar
- White Folding Handle
- Interior Aluminum Screen
- Bright View Mesh
- White Surround
- 4 9/16" Jambs
- Nailing Fin



Materials: Qty 24: WM327 (2-1/4" Clamshell) ** NON-TAXABLE ITEM

Labor: Qty 1: Full Jamb Install ** NON-TAXABLE ITEM

***Note: Unit Availability and Price is Subject to Change

Initials required

Seller: _____

Buyer: _____

| | | | | |
|---------|------------------------|--|--|--|
| Line #9 | Mark Unit: Basement W8 | | | |
| Qty: 1 | | | | |

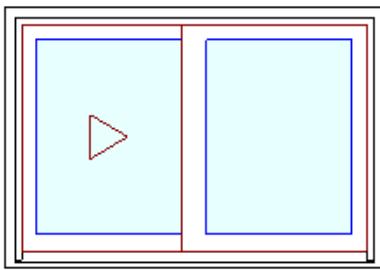

As Viewed From The Exterior

Entered As: CN
 CN 3624
 FS 35 1/2" X 23 3/4"
 RO 36 1/2" X 24 1/4"
Egress Information
 Width: 14 1/8" Height: 19 37/64"
 Net Clear Opening: 1.92 SqFt

Stone White Exterior
 White Interior
 Elevate Glider - XO
 CN 3624
 Rough Opening 36 1/2" X 24 1/4"
 Left Sash
 Stone White Exterior
 White Interior
 IG - 1 Lite
 Low E2 w/Argon
 Stainless Perimeter Bar
 Right Sash
 Stone White Exterior
 White Interior
 IG - 1 Lite
 Low E2 w/Argon
 Stainless Perimeter Bar
 White Weather Strip Package
 1 White Sash Lock
 Exterior Aluminum Half Screen
 Stone White Surround
 Bright View Mesh
 4 9/16" Jamb
 Nailing Fin



REVIEWED
 By Dan.Bruechert at 3:32 pm, Nov 13, 2023

Materials: Qty 24: WM327 (2-1/4" Clamshell) ** NON-TAXABLE ITEM

Labor: Qty 1: Full Jamb Install ** NON-TAXABLE ITEM

***Note: Unit Availability and Price is Subject to Change

Initials required

Seller: _____

Buyer: _____

| | | | | |
|----------|------------------------|--|--|--|
| Line #10 | Mark Unit: Basement W9 | | | |
| Qty: 1 | | | | |



Stone White Exterior
 White Interior
 Elevate Double Hung
 Frame Size 36" X 48"
 Rough Opening 37" X 48 1/2"
 Top Sash
 Stone White Exterior
 White Interior
 IG - 1 Lite
 Low E2 w/Argon
 Stainless Perimeter Bar
 Bottom Sash

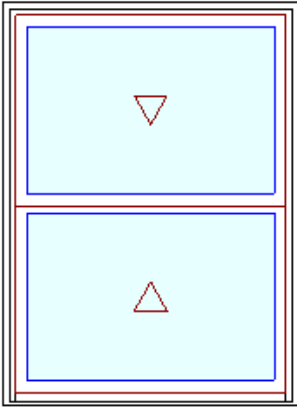

As Viewed From The Exterior

Stone White Exterior
 White Interior
 IG - 1 Lite
 Low E2 w/Argon
 Stainless Perimeter Bar
 White Weather Strip Package
 1 White Sash Lock
 Exterior Aluminum Screen
 Stone White Surround
 Bright View Mesh
 4 9/16" Jamb
 Nailing Fin

Materials: Qty 24: WM327 (2-1/4" Clamshell) ** NON-TAXABLE ITEM

Labor: Qty 1: Full Jamb Install ** NON-TAXABLE ITEM

***Note: Unit Availability and Price is Subject to Change

Entered As: FS
 FS 36" X 48"
 RO 37" X 48 1/2"
Egress Information
 Width: 32 7/8" Height: 19 3/32"
 Net Clear Opening: 4.36 SqFt

Initials required
 Seller: _____
 Buyer: _____

| | | |
|----------|----------------------------------|--|
| Line #11 | Mark Unit: Basement Casement W10 | |
| Qty: 1 | | |

APPROVED
 Montgomery County
 Historic Preservation Commission

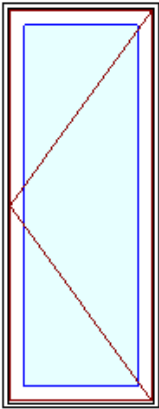
As Viewed From The Exterior

Stone White Exterior
 White Interior
 Elevate Casement - Left Hand
 Frame Size 19" X 48"
 Rough Opening 20" X 48 1/2"
 Stone White Exterior
 White Interior
 IG - 1 Lite
 Low E2 w/Argon
 Stainless Perimeter Bar
 White Folding Handle
 Interior Aluminum Screen
 Bright View Mesh
 White Surround
 4 9/16" Jamb
 Nailing Fin

Materials: Qty 24: WM327 (2-1/4" Clamshell) ** NON-TAXABLE ITEM

Labor: Qty 1: Full Jamb Install ** NON-TAXABLE ITEM

***Note: Unit Availability and Price is Subject to Change

Entered As: FS
 FS 19" X 48"
 RO 20" X 48 1/2"
Egress Information
 Width: 10 15/64" Height: 43 19/32"
 Net Clear Opening: 3.10 SqFt

Initials required
 Seller: _____
 Buyer: _____

REVIEWED
 By Dan.Bruechert at 3:32 pm, Nov 13, 2023

| | | | | |
|----------|-------------------------|--|--|--|
| Line #12 | Mark Unit: Basement W11 | | | |
| Qty: 1 | | | | |



Stone White Exterior
 White Interior
 Elevate Glider Triple Sash - XOX
 Frame Size 82" X 53"
 Rough Opening 83" X 53 1/2"
 Left Sash
 Stone White Exterior

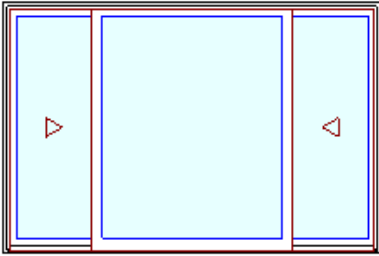

As Viewed From The Exterior

Entered As: FS
 FS 82" X 53"
 RO 83" X 53 1/2"
Egress Information
 Width: 18 19/64" Height: 48 53/64"
 Net Clear Opening: 6.20 SqFt

- White Interior
- IG - 1 Lite
- Low E2 w/Argon
- Stainless Perimeter Bar
- Center Sash
- Stone White Exterior
- White Interior
- IG - 1 Lite
- Low E2 w/Argon
- Stainless Perimeter Bar
- Right Sash
- Stone White Exterior
- White Interior
- IG - 1 Lite
- Low E2 w/Argon
- Stainless Perimeter Bar
- White Weather Strip Package
- 2 White Sash Lock
- Exterior Aluminum Half Screen
- Stone White Surround
- Bright View Mesh
- 4 9/16" Jambs
- Nailing Fin

Materials: Qty 24: WM327 (2-1/4" Clamshell) ** NON-TAXABLE ITEM

Labor: Qty 1: Full Jamb Install ** NON-TAXABLE ITEM
*****Note: Unit Availability and Price is Subject to Change**

Initials required

Seller: _____

Buyer: _____

| | |
|----------|-------------------------|
| Line #13 | Mark Unit: Basement W12 |
| Qty: 1 | |

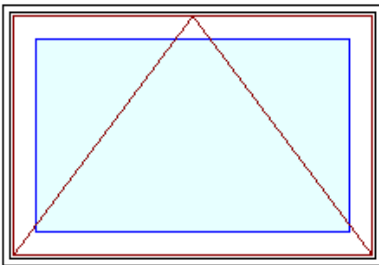

As Viewed From The Exterior

Entered As: FS
 FS 30" X 20"
 RO 31" X 20 1/2"
Egress Information
 No Egress Information available.

- Stone White Exterior
- White Interior
- Elevate Awning - Roto Operating
- Frame Size 30" X 20"
- Rough Opening 31" X 20 1/2"
- Stone White Exterior
- White Interior
- IG - 1 Lite
- Low E2 w/Argon
- Stainless Perimeter Bar
- White Folding Handle
- Interior Aluminum Screen
- Bright View Mesh
- White Surround
- 4 9/16" Jambs
- Nailing Fin

Materials: Qty 24: WM327 (2-1/4" Clamshell) ** NON-TAXABLE ITEM

Labor: Qty 1: Full Jamb Install ** NON-TAXABLE ITEM
*****Note: Unit Availability and Price is Subject to Change**

APPROVED

Montgomery County

Historic Preservation Commission



REVIEWED

By Dan.Bruechert at 3:32 pm, Nov 13, 2023

Initials required

Seller: _____

Buyer: _____

| | | | | |
|--------------------|-----------------------|--|--|--|
| Line #14 Qty: 1 | Mark Unit: Garage W13 | | | |
|--------------------|-----------------------|--|--|--|

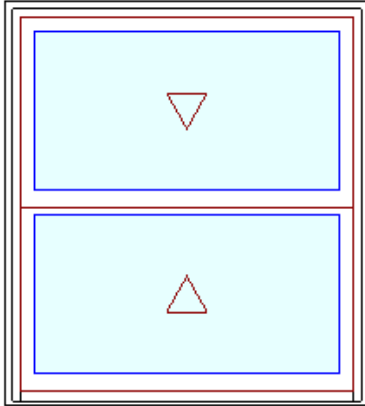

As Viewed From The Exterior

Entered As: FS
FS 36" X 39"
RO 37" X 39 1/2"
Egress Information
 Width: 32 7/8" Height: 14 19/32"
 Net Clear Opening: 3.33 SqFt

Stone White Exterior
 White Interior
 Elevate Double Hung
 Frame Size 36" X 39"
 Rough Opening 37" X 39 1/2"
 Top Sash
 Stone White Exterior
 White Interior
 IG - 1 Lite
 Low E2 w/Argon
 Stainless Perimeter Bar
 Bottom Sash
 Stone White Exterior
 White Interior
 IG - 1 Lite
 Low E2 w/Argon
 Stainless Perimeter Bar
 White Weather Strip Package
 1 White Sash Lock
 Exterior Aluminum Screen
 Stone White Surround
 Bright View Mesh
 4 9/16" Jamb
 Nailing Fin

Materials: Qty 24: WM327 (2-1/4" Clamshell) ** NON-TAXABLE ITEM

Labor: Qty 1: Full Jamb Install ** NON-TAXABLE ITEM

***Note: Unit Availability and Price is Subject to Change

Initials required

Seller: _____

Buyer: _____

| | | | | |
|--------------------|-------------------------------------|--|--|--|
| Line #15 Qty: 1 | Mark Unit: 2nd floor W14 - build up | | | |
|--------------------|-------------------------------------|--|--|--|

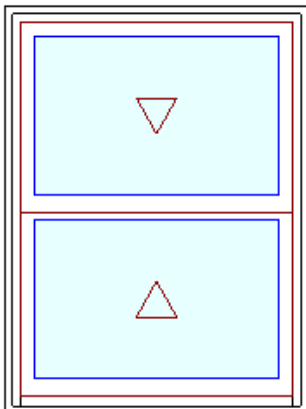

As Viewed From The Exterior

Entered As: FS
FS 30" X 39"
RO 31" X 39 1/2"
Egress Information
 Width: 26 7/8" Height: 14 19/32"

Stone White Exterior
 White Interior
 Elevate Double Hung
 Frame Size 30" X 39"
 Rough Opening 31" X 39 1/2"
 Top Sash
 Stone White Exterior
 White Interior
 IG - 1 Lite
 Low E2 w/Argon
 Stainless Perimeter Bar
 Bottom Sash
 Stone White Exterior
 White Interior
 IG - 1 Lite
 Low E2 w/Argon
 Stainless Perimeter Bar
 White Weather Strip Package
 1 White Sash Lock
 Exterior Aluminum Screen
 Stone White Surround
 Bright View Mesh
 4 9/16" Jamb
 Nailing Fin



Net Clear Opening: 2.72 SqFt

Materials: Qty 24: WM327 (2-1/4" Clamshell) ** NON-TAXABLE ITEM

Labor: Qty 1: Full Jamb Install ** NON-TAXABLE ITEM

*****Note: Unit Availability and Price is Subject to Change**

Initials required

Seller: _____

Buyer: _____

APPROVED
Montgomery County
Historic Preservation Commission



REVIEWED
By Dan.Bruechert at 3:31 pm, Nov 13, 2023

APPROVED
 Montgomery County
 Historic Preservation Commission



REVIEWED
 By Dan.Bruechert at 3:33 pm, Nov 13, 2023

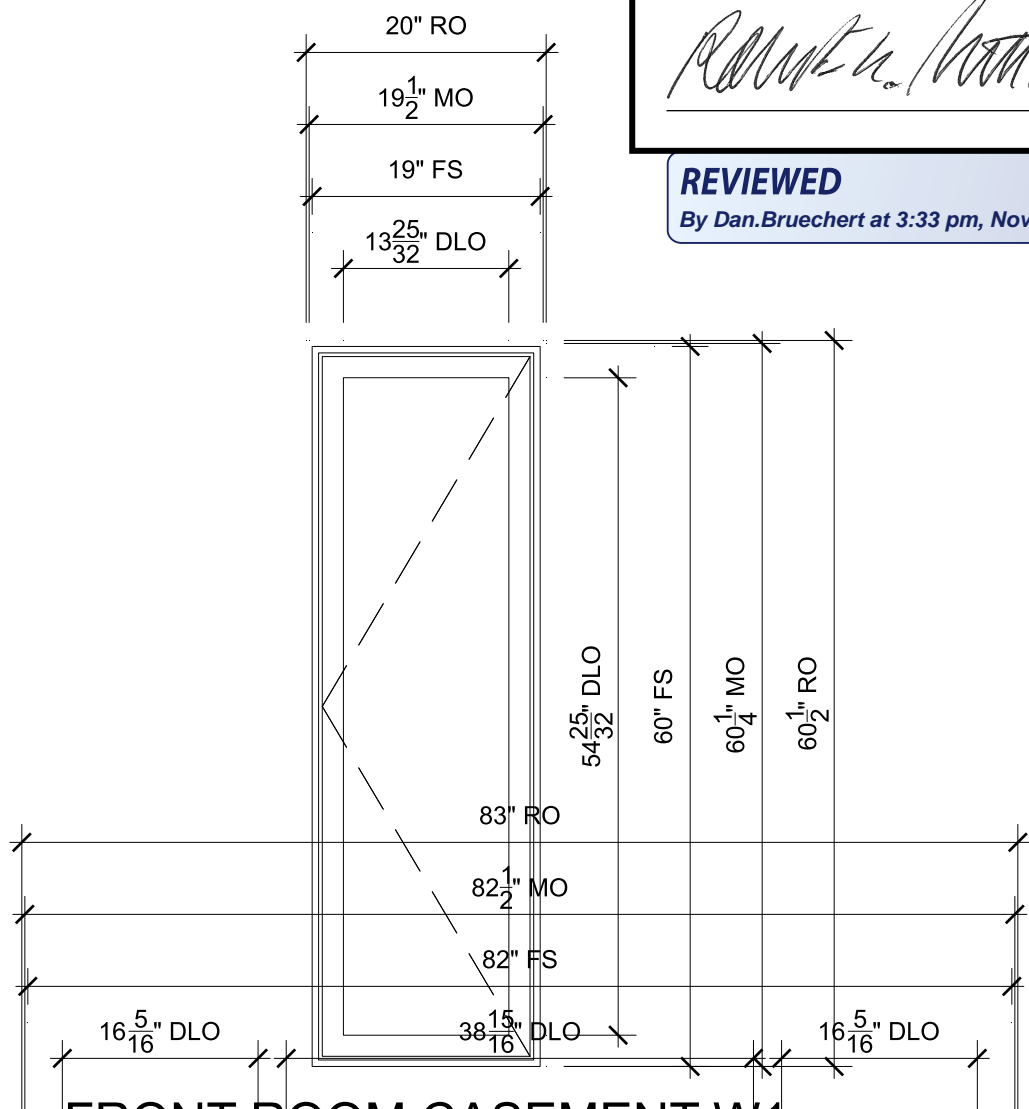

FRONT ROOM CASEMENT W1

SCALE: 3/4" = 1'-0"

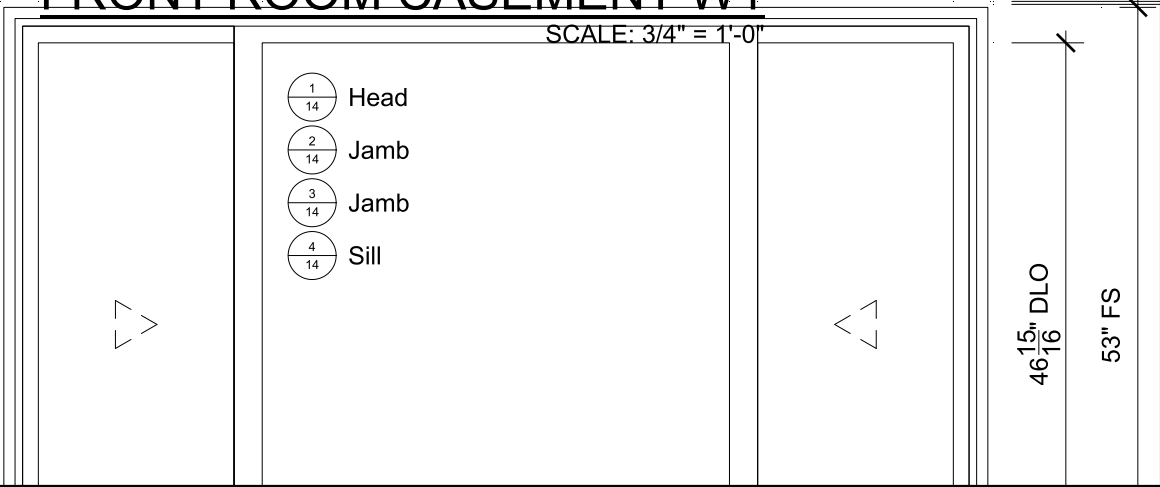

- 1/14 Head
- 2/14 Jamb
- 3/14 Jamb
- 4/14 Sill



PROJ/JOB: Kelleher / Elevate
 DIST/DEALER: ALCO PRODUCTS COMPANY INC-CIR
 DRAWN: MICHELLE REYNOLDS
 QUOTE#: 6DWAX6R PK VER: 0004.04.00 CREATED: 11/06/2023 REVISION:

SHEET
 1
 OF 21

APPROVED
 Montgomery County
 Historic Preservation Commission





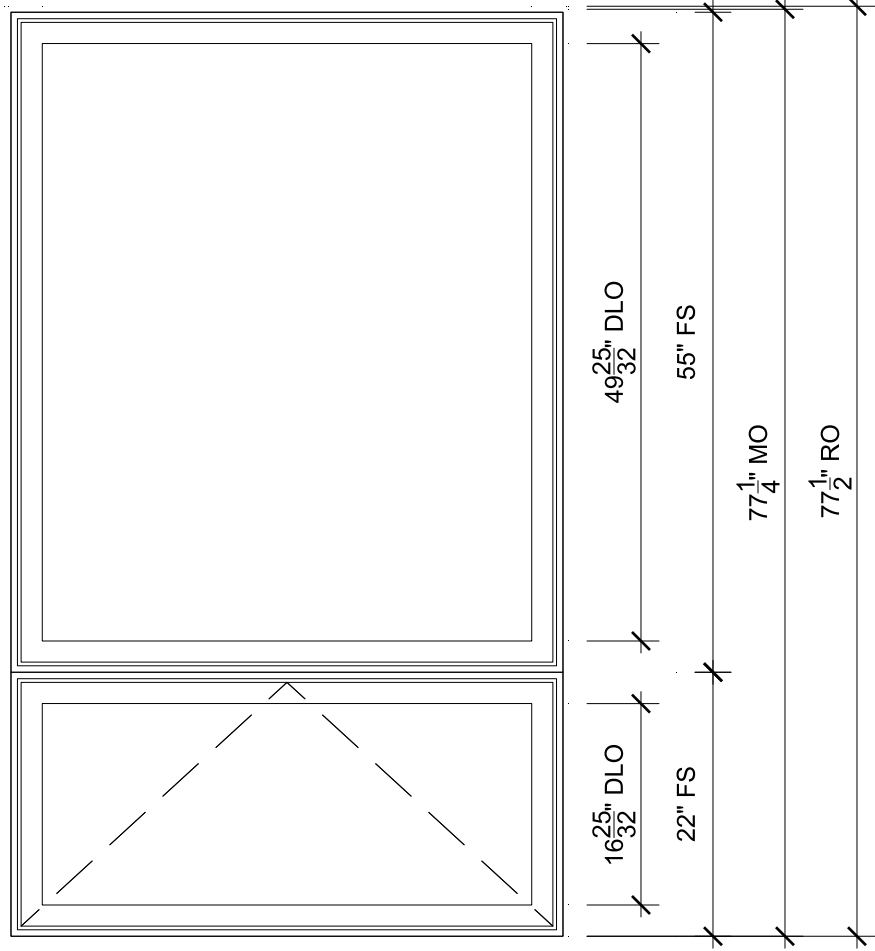
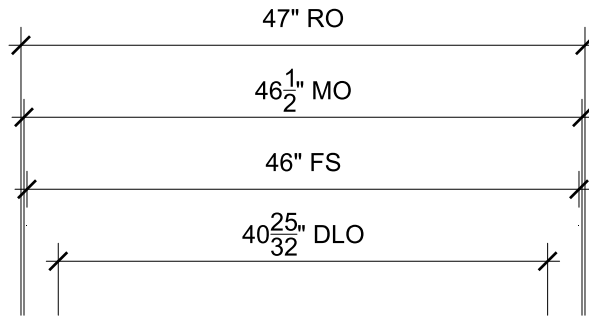

REVIEWED

By Dan.Bruechert at 3:33 pm, Nov 13, 2023



LIVING ROOM W2

SCALE: 3/4" = 1'-0"

-  Head
-  Horizontal Mullion
-  Jamb
-  Jamb
-  Sill



PROJ/JOB: Kelleher / Elevate
 DIST/DEALER: ALCO PRODUCTS COMPANY INC-CIR
 DRAWN: MICHELLE REYNOLDS
 QUOTE#: 6DWAX6R PK VER: 0004.04.00

CREATED: 11/06/2023 REVISION:

SHEET
 2
 OF 21

REVIEWED

By Dan.Bruechert at 3:33 pm, Nov 13, 2023

APPROVED

Montgomery County
Historic Preservation Commission

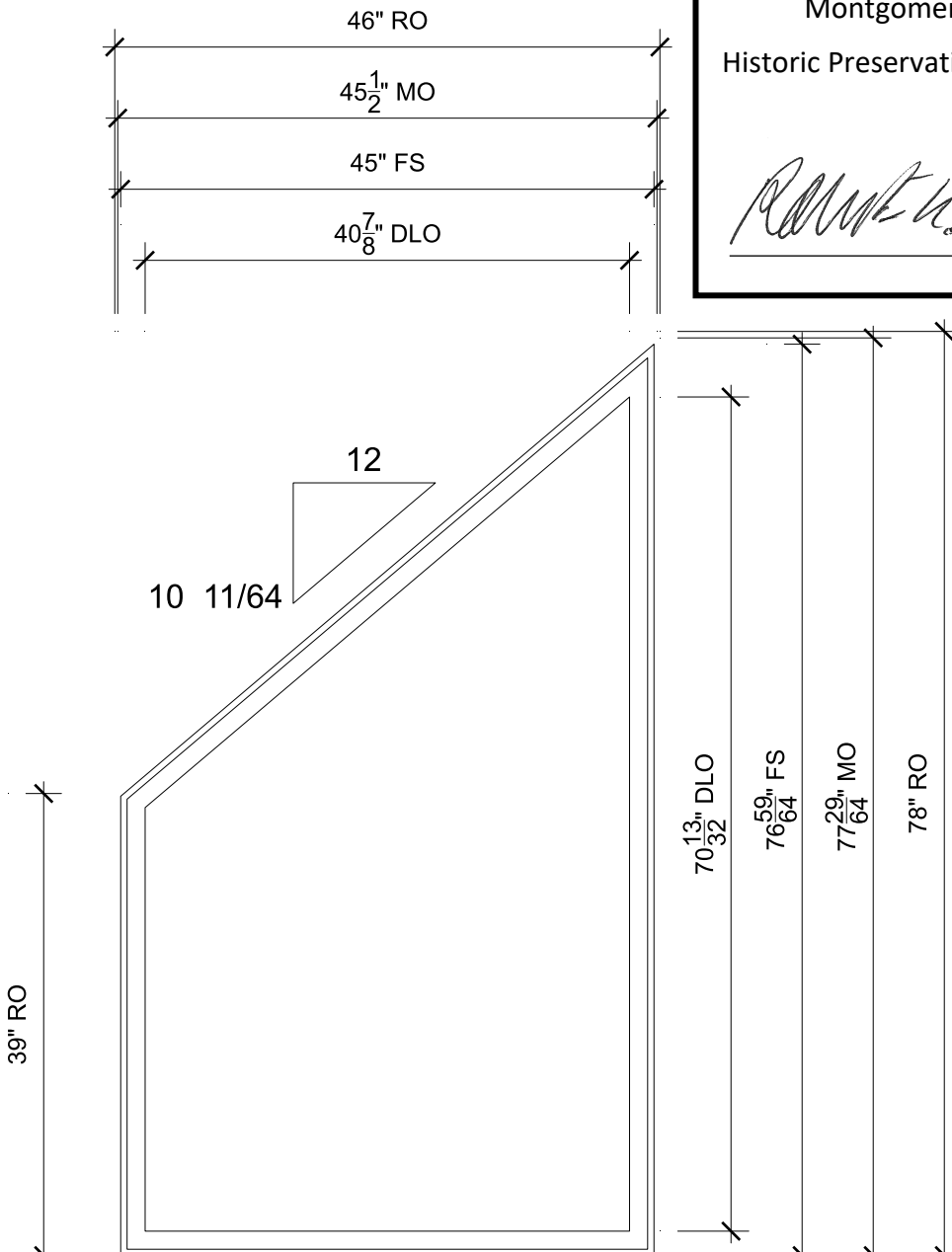

POLYGON WINDOW W3

SCALE: 3/4" = 1'-0"

$\frac{1}{16}$ Head

$\frac{2}{16}$ Jamb

$\frac{3}{16}$ Sill



PROJ/JOB: Kelleher / Elevate
DIST/DEALER: ALCO PRODUCTS COMPANY INC-CIR
DRAWN: MICHELLE REYNOLDS
QUOTE#: 6DWAX6R PK VER: 0004.04.00

CREATED: 11/06/2023 REVISION:

SHEET
3
OF 21

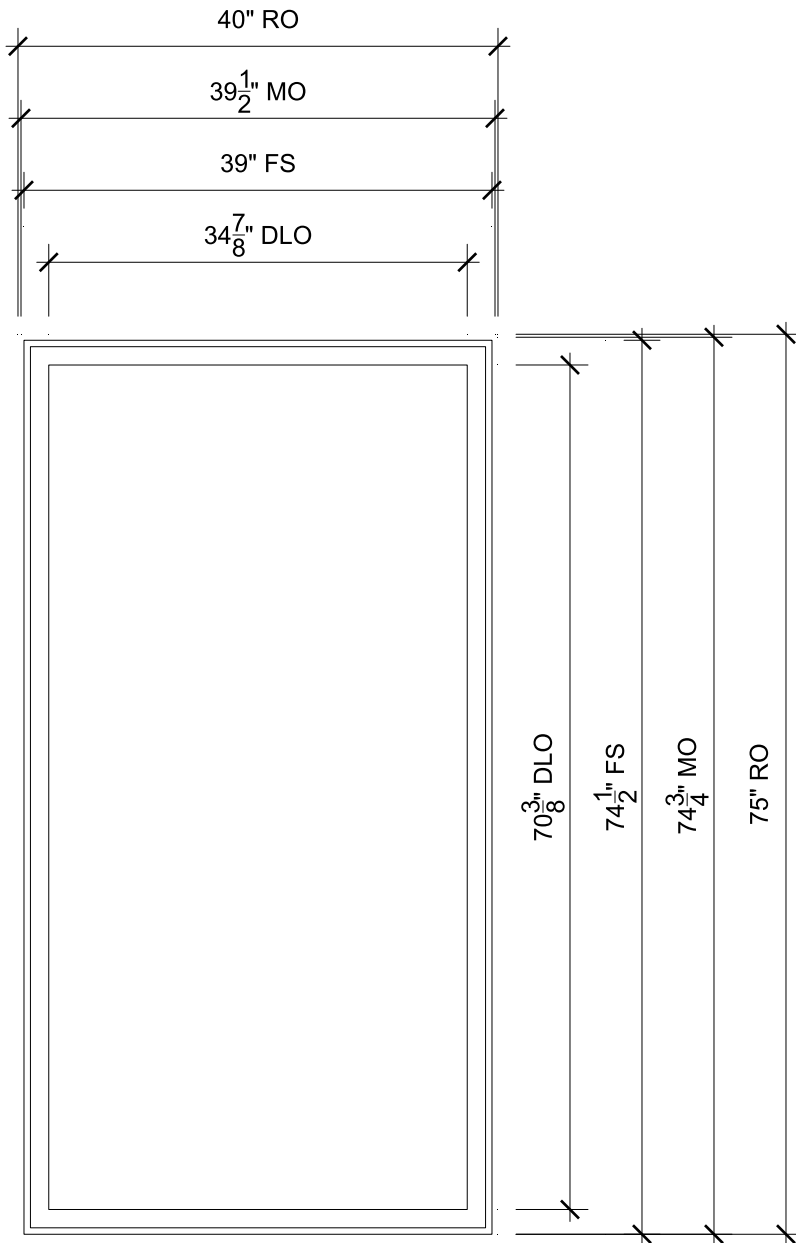

EATING AREA W4
SCALE: 3/4" = 1'-0"

$\frac{4}{16}$ Head
 $\frac{2}{17}$ Sill

$\frac{1}{17}$ Jamb

REVIEWED

By Dan.Bruechert at 3:33 pm, Nov 13, 2023

APPROVED
Montgomery County
Historic Preservation Commission

Robert H. [Signature]



PROJ/JOB: Kelleher / Elevate
DIST/DEALER: ALCO PRODUCTS COMPANY INC-CIR
DRAWN: MICHELLE REYNOLDS
QUOTE#: 6DWAX6R PK VER: 0004.04.00

CREATED: 11/06/2023 REVISION:

SHEET
4
OF 21

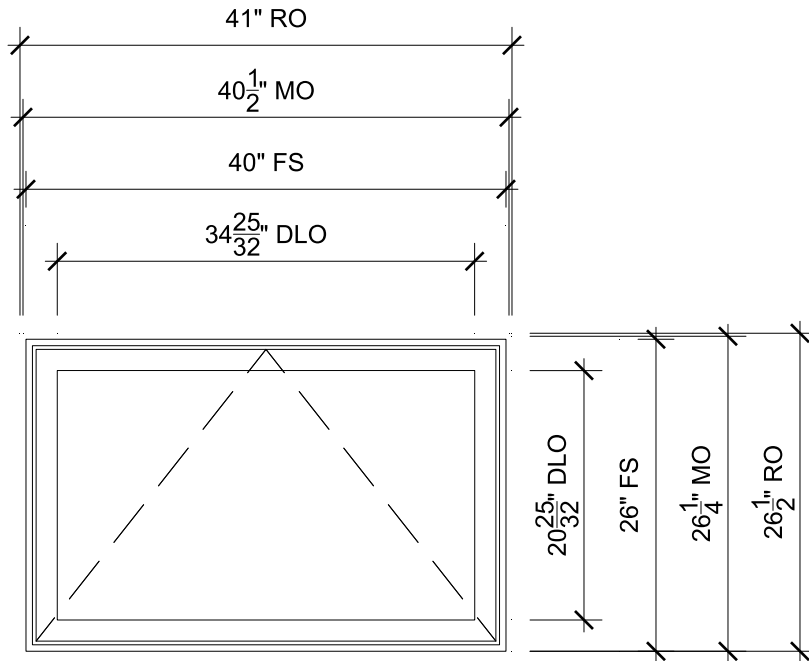

EATING AREA W5

SCALE: 3/4" = 1'-0"

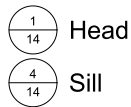

APPROVED
 Montgomery County
 Historic Preservation Commission



REVIEWED
 By Dan.Bruechert at 3:33 pm, Nov 13, 2023



PROJ/JOB: Kelleher / Elevate
 DIST/DEALER: ALCO PRODUCTS COMPANY INC-CIR
 DRAWN: MICHELLE REYNOLDS
 QUOTE#: 6DWAX6R PK VER: 0004.04.00

CREATED: 11/06/2023 REVISION:

SHEET
 5
 OF 21

REVIEWED

By Dan.Bruechert at 3:32 pm, Nov 13, 2023

APPROVED

Montgomery County
Historic Preservation Commission

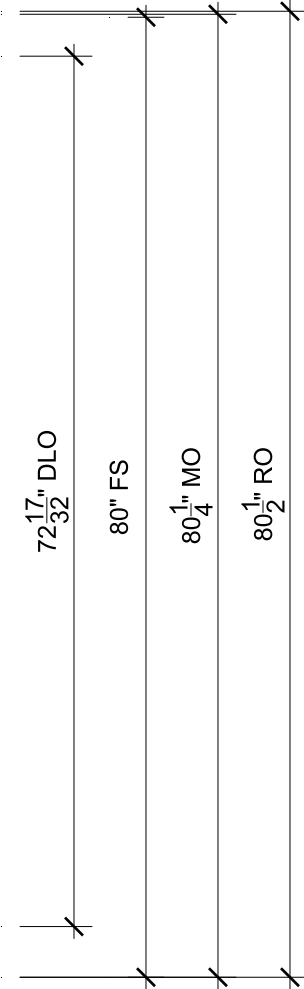
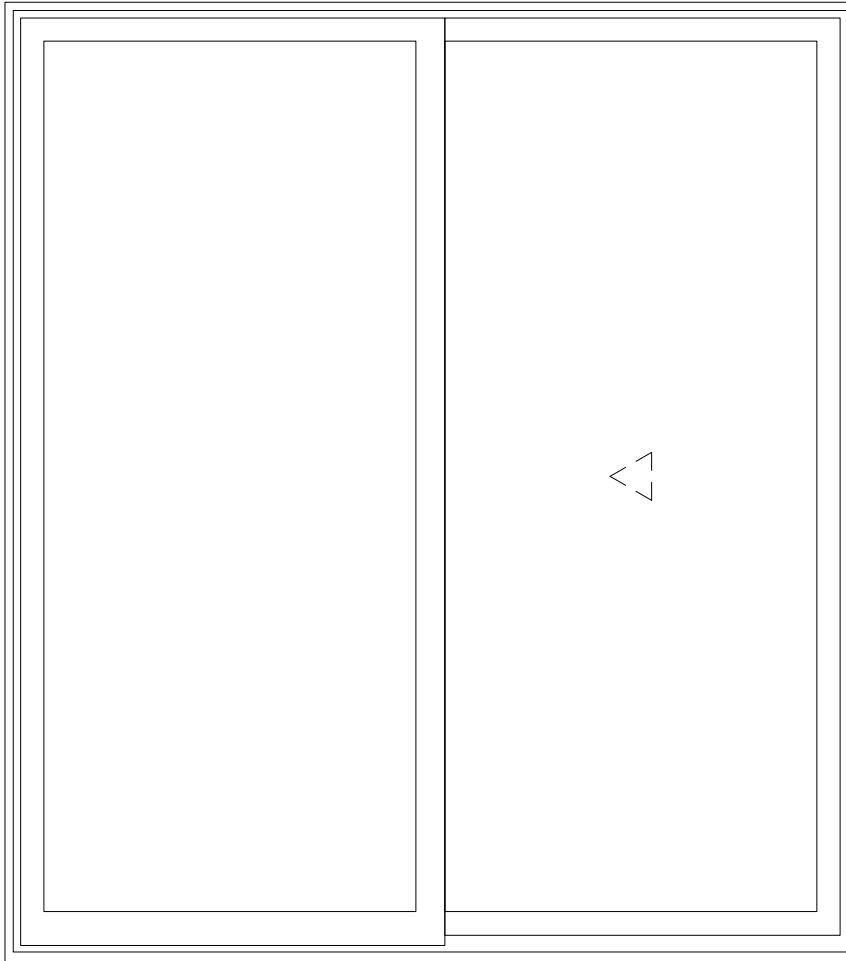
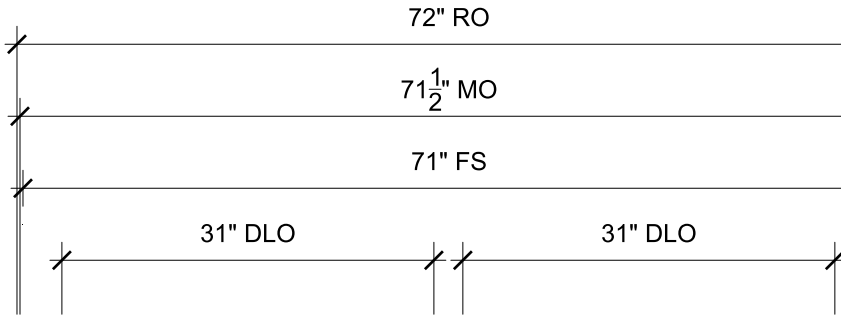

SLIDING DOOR W6

SCALE: 3/4" = 1'-0"



Head



Jamb



Jamb



Sill



Meeting Stile



PROJ/JOB: Kelleher / Elevate
DIST/DEALER: ALCO PRODUCTS COMPANY INC-CIR
DRAWN: MICHELLE REYNOLDS
QUOTE#: 6DWAX6R PK VER: 0004.04.00

CREATED: 11/06/2023 REVISION:



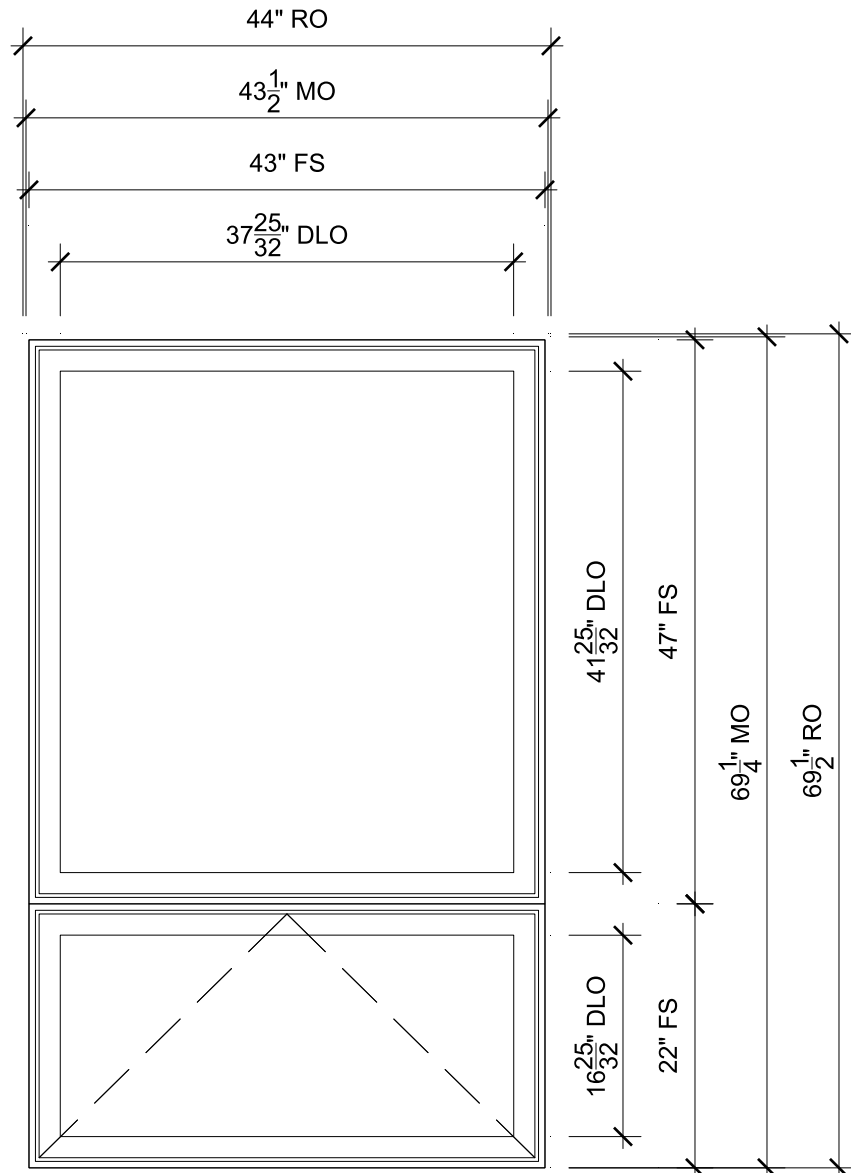

SHEET

6

OF 21



REAR OF HOME W7
 SCALE: 3/4" = 1'-0"

-  Head
-  Horizontal Mullion
-  Jamb
-  Jamb
-  Sill

APPROVED
 Montgomery County
 Historic Preservation Commission

[Signature]

REVIEWED
 By Dan.Bruechert at 3:33 pm, Nov 13, 2023



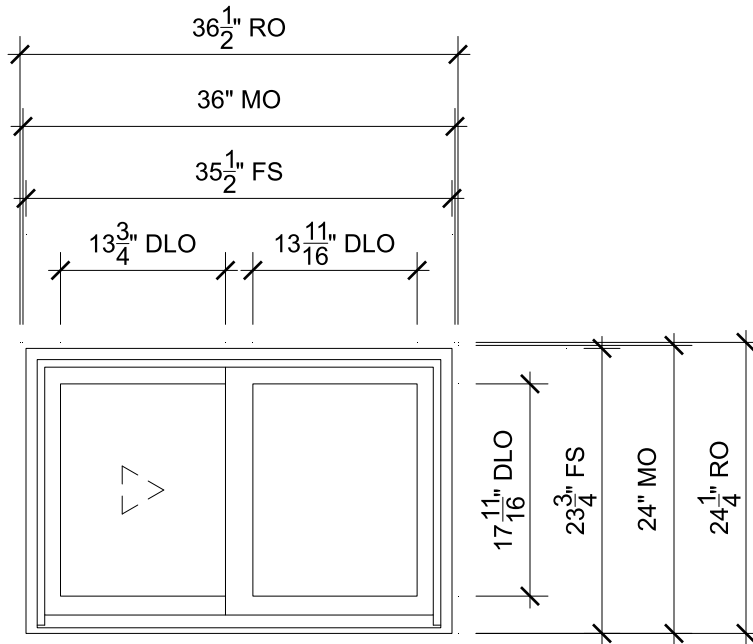

BASEMENT W8

SCALE: 3/4" = 1'-0"

-  Head
-  Jamb
-  Jamb
-  Sill
-  Meeting Stile

APPROVED
 Montgomery County
 Historic Preservation Commission

[Signature]

REVIEWED
 By Dan.Bruechert at 3:33 pm, Nov 13, 2023



PROJ/JOB: Kelleher / Elevate
 DIST/DEALER: ALCO PRODUCTS COMPANY INC-CIR
 DRAWN: MICHELLE REYNOLDS
 QUOTE#: 6DWAX6R PK VER: 0004.04.00



CREATED: 11/06/2023 REVISION:

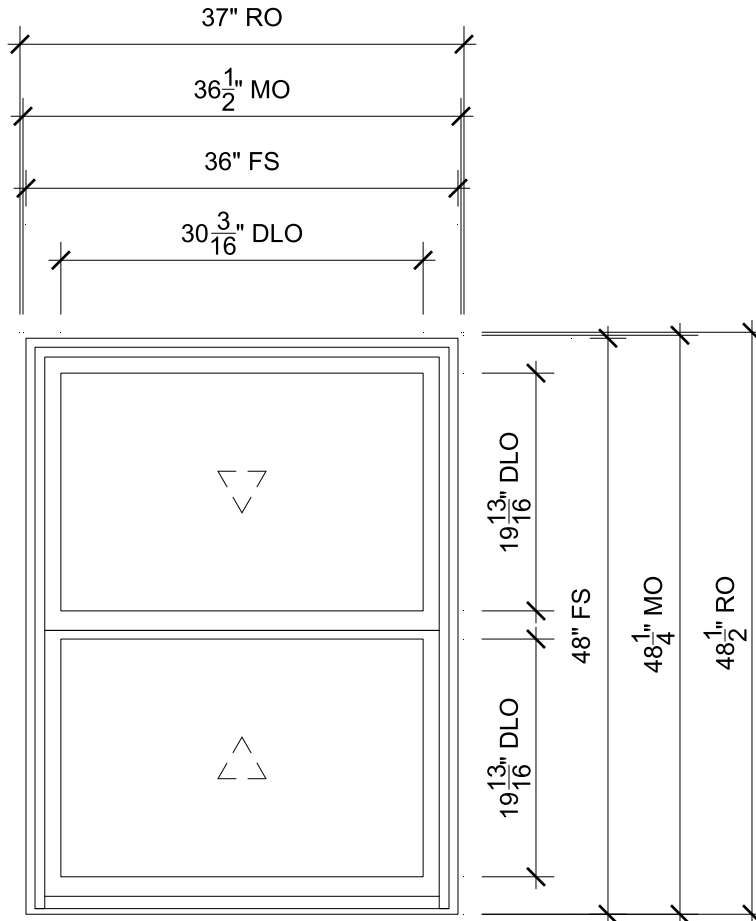

SHEET
 8
 OF 21



BASEMENT W9

SCALE: 3/4" = 1'-0"

-  Head
-  Sill

-  Jamb
-  Check Rail

APPROVED

Montgomery County
Historic Preservation Commission



REVIEWED
By Dan.Bruechert at 3:33 pm, Nov 13, 2023



PROJ/JOB: Kelleher / Elevate
 DIST/DEALER: ALCO PRODUCTS COMPANY INC-CIR
 DRAWN: MICHELLE REYNOLDS
 QUOTE#: 6DWAX6R PK VER: 0004.04.00

CREATED: 11/06/2023 REVISION:

SHEET
9
OF 21

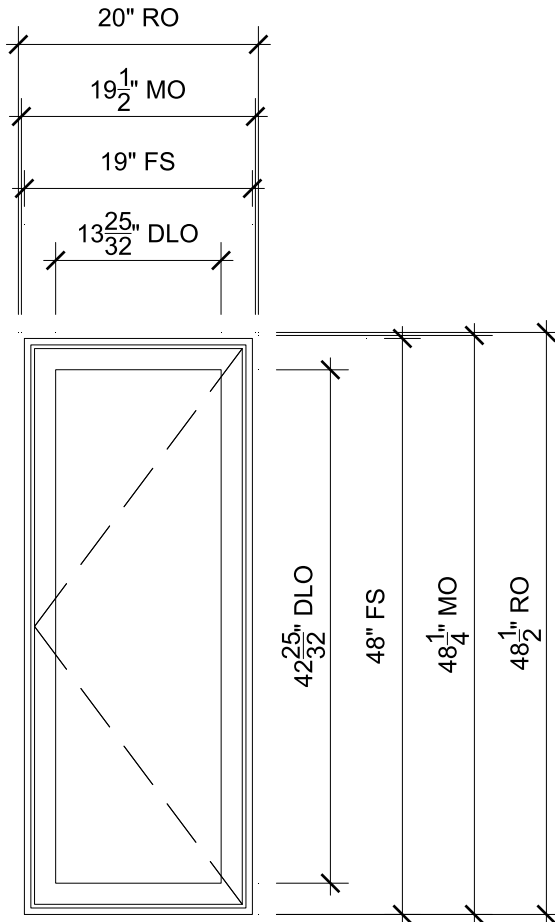

BASEMENT CASEMENT W10

SCALE: 3/4" = 1'-0"

- 1/14 Head
- 2/14 Jamb
- 3/14 Jamb
- 4/14 Sill

APPROVED
 Montgomery County
 Historic Preservation Commission

[Signature]

REVIEWED
 By Dan.Bruechert at 3:33 pm, Nov 13, 2023



PROJ/JOB: Kelleher / Elevate
 DIST/DEALER: ALCO PRODUCTS COMPANY INC-CIR
 DRAWN: MICHELLE REYNOLDS
 QUOTE#: 6DWAX6R PK VER: 0004.04.00

CREATED: 11/06/2023 REVISION:

SHEET
 10
 OF 21

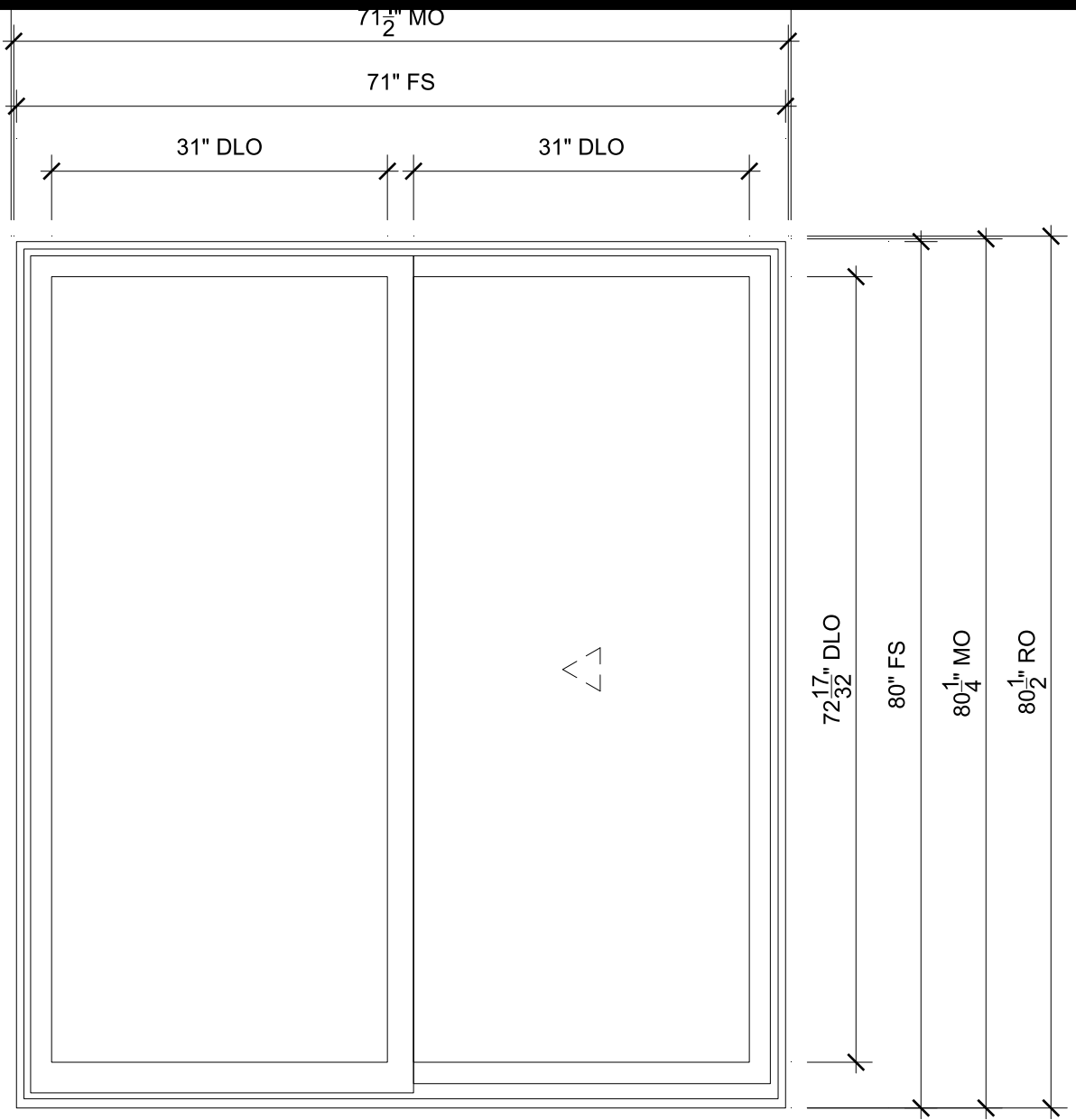

SLIDING DOOR W6

SCALE: 3/4" = 1'-0"



Head



Jamb



Jamb



Sill



Meeting Stile

REVIEWED

By Dan.Bruechert at 3:34 pm, Nov 13, 2023

APPROVED

Montgomery County
Historic Preservation Commission



PROJ/JOB: Kelleher / Elevate
DIST/DEALER: ALCO PRODUCTS COMPANY INC-CIR
DRAWN: MICHELLE REYNOLDS
QUOTE#: 6DWAX6R PK VER: 0004.04.00

CREATED: 11/06/2023 REVISION:

SHEET

11

OF 21

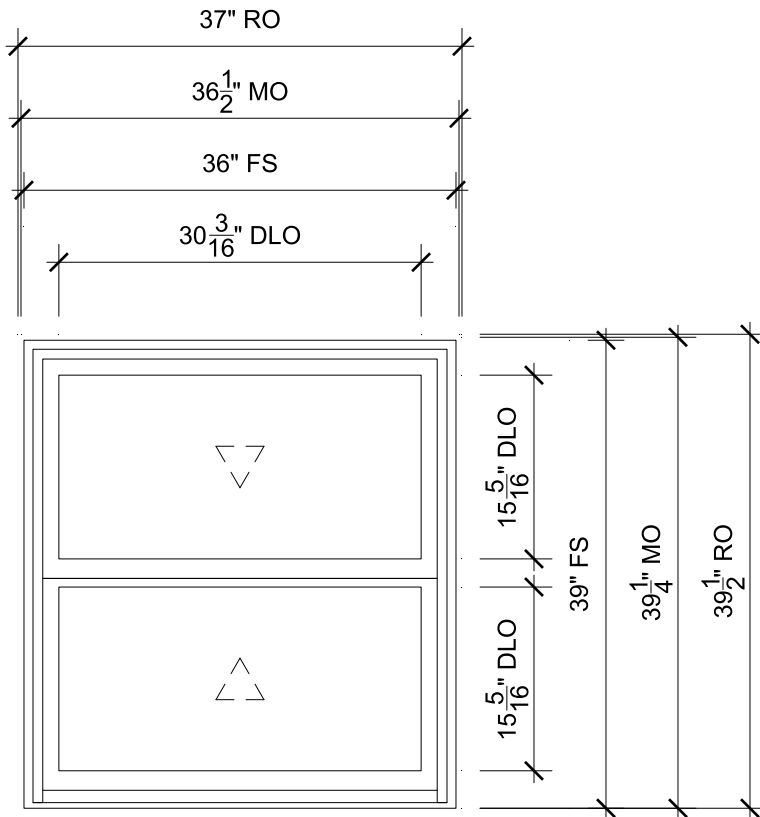

GARAGE W13

SCALE: 3/4" = 1'-0"

1/20 Head
3/20 Sill

2/20 Jamb
4/21 Check Rail

APPROVED
Montgomery County
Historic Preservation Commission
Ronald L. ...

REVIEWED
By Dan.Bruechert at 3:34 pm, Nov 13, 2023



PROJ/JOB: Kelleher / Elevate
DIST/DEALER: ALCO PRODUCTS COMPANY INC-CIR
DRAWN: MICHELLE REYNOLDS
QUOTE#: 6DWAX6R PK VER: 0004.04.00

CREATED: 11/06/2023 REVISION:

SHEET
12
OF 21

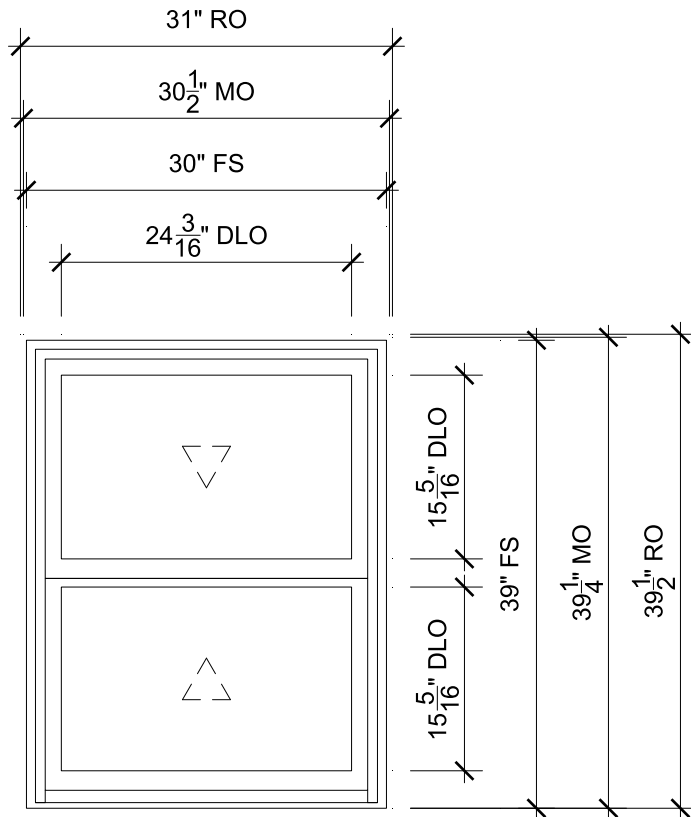

2ND FLOOR W14 - BUILD UP
 SCALE: 3/4" = 1'-0"

- 1
20 Head
- 2
20 Jamb
- 3
20 Sill
- 4
21 Check Rail

APPROVED
 Montgomery County
 Historic Preservation Commission

[Signature]

REVIEWED
 By Dan.Bruechert at 3:34 pm, Nov 13, 2023



PROJ/JOB: Kelleher / Elevate
 DIST/DEALER: ALCO PRODUCTS COMPANY INC-CIR
 DRAWN: MICHELLE REYNOLDS
 QUOTE#: 6DWAX6R PK VER: 0004.04.00

CREATED: 11/06/2023 REVISION:

SHEET
 13
 OF 21

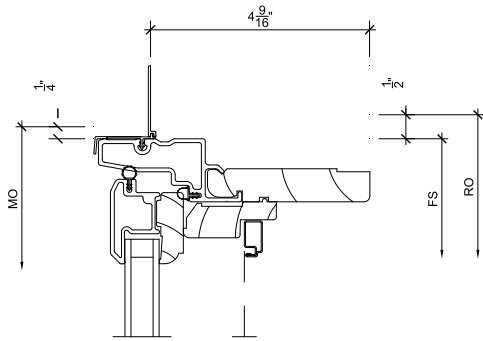

1 Head
14 SCALE: 3" = 1'-0"

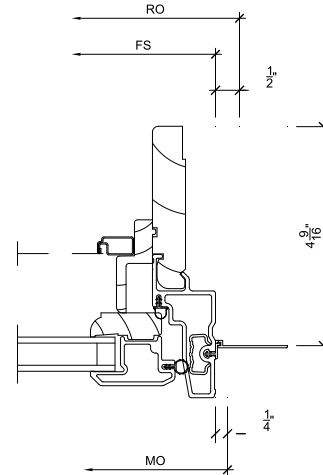

3 Jamb
14 SCALE: 3" = 1'-0"

REVIEWED
By Dan.Bruechert at 3:34 pm, Nov 13, 2023

APPROVED
Montgomery County
Historic Preservation Commission
[Signature]

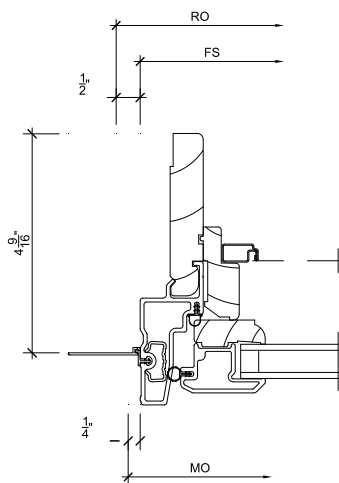

2 Jamb
14 SCALE: 3" = 1'-0"

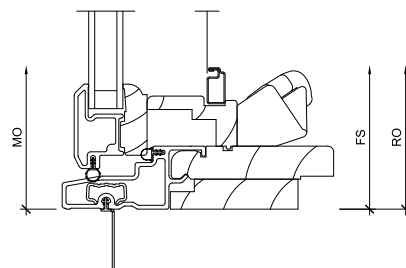

4 Sill
14 SCALE: 3" = 1'-0"

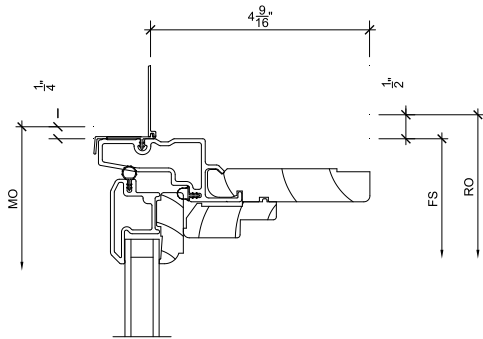

1 Head
15 SCALE: 3" = 1'-0"

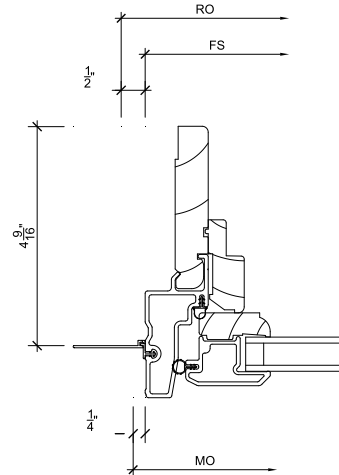

3 Jamb
15 SCALE: 3" = 1'-0"

REVIEWED

By Dan.Bruechert at 3:34 pm, Nov 13, 2023

APPROVED
Montgomery County
Historic Preservation Commission
[Signature]

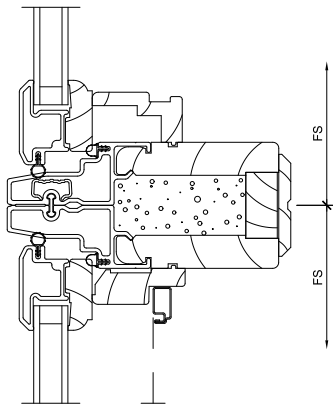

2 Horizontal Mullion
15 SCALE: 3" = 1'-0"

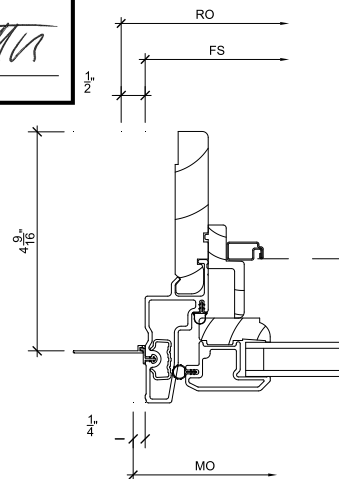

4 Jamb
15 SCALE: 3" = 1'-0"



PROJ/JOB: Kelleher / Elevate
DIST/DEALER: ALCO PRODUCTS COMPANY INC-CIR
DRAWN: MICHELLE REYNOLDS
QUOTE#: 6DWAX6R PK VER: 0004.04.00

CREATED: 11/06/2023 REVISION:

SHEET
15
OF 21

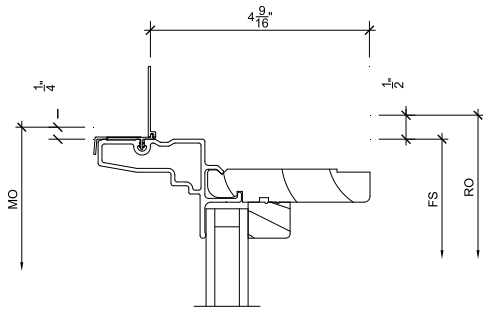

1 Head SCALE: 3" = 1'-0"

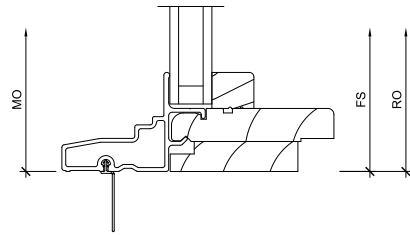

3 Sill SCALE: 3" = 1'-0"

REVIEWED

By Dan.Bruechert at 3:34 pm, Nov 13, 2023

APPROVED
 Montgomery County
 Historic Preservation Commission
Michelle Reynolds

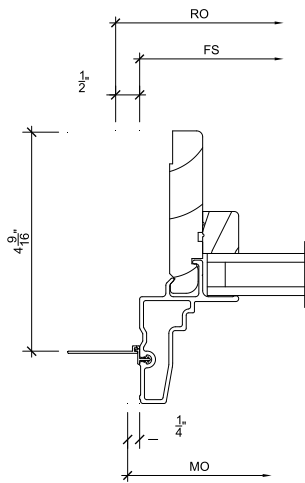

2 Jamb SCALE: 3" = 1'-0"

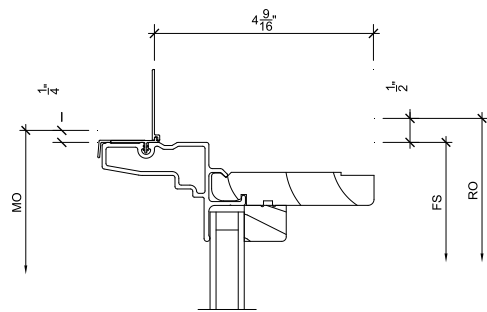

4 Head SCALE: 3" = 1'-0"



PROJ/JOB: Kelleher / Elevate
 DIST/DEALER: ALCO PRODUCTS COMPANY INC-CIR
 DRAWN: MICHELLE REYNOLDS
 QUOTE#: 6DWAX6R PK VER: 0004.04.00

CREATED: 11/06/2023 REVISION:

SHEET
 16
 OF 21

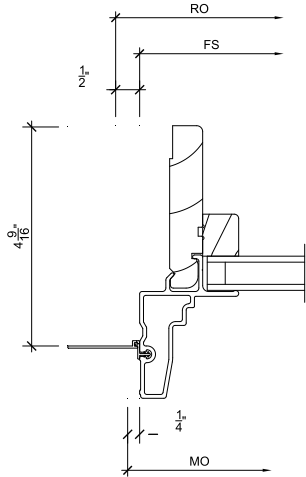

1
17

Jamb

SCALE: 3" = 1'-0"

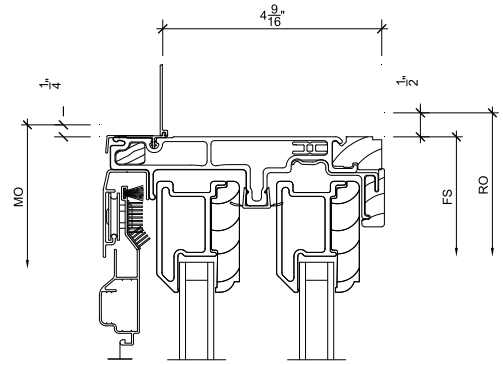

3
17

Head

SCALE: 3" = 1'-0"

REVIEWED

By Dan.Bruechert at 3:35 pm, Nov 13, 2023

APPROVED
Montgomery County
Historic Preservation Commission

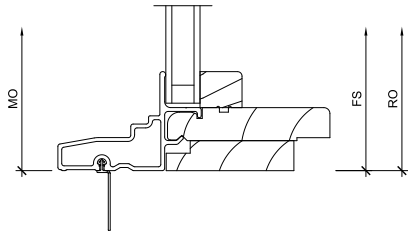

2
17

Sill

SCALE: 3" = 1'-0"

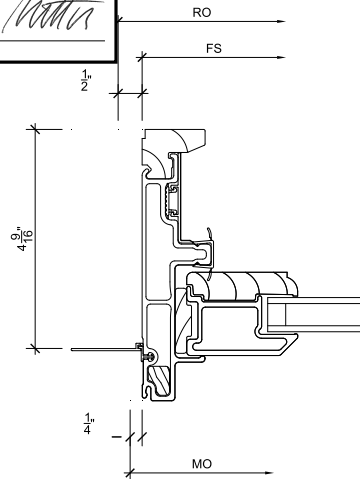

4
17

Jamb

SCALE: 3" = 1'-0"



PROJ/JOB: Kelleher / Elevate
DIST/DEALER: ALCO PRODUCTS COMPANY INC-CIR
DRAWN: MICHELLE REYNOLDS
QUOTE#: 6DWAX6R PK VER: 0004.04.00

CREATED: 11/06/2023 REVISION:

SHEET
17
OF 21

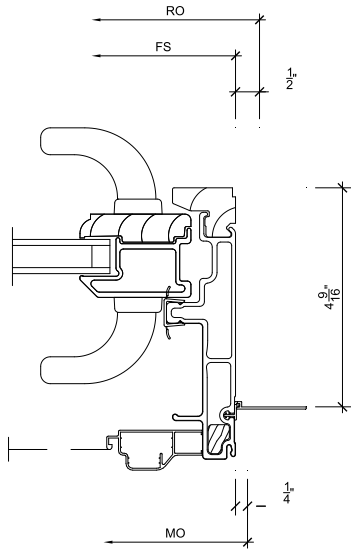

1
18

Jamb

SCALE: 3" = 1'-0"

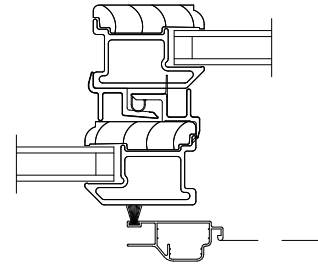

3
18

Meeting Stile

SCALE: 3" = 1'-0"

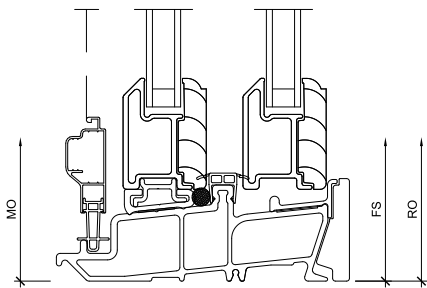

2
18

Sill

SCALE: 3" = 1'-0"

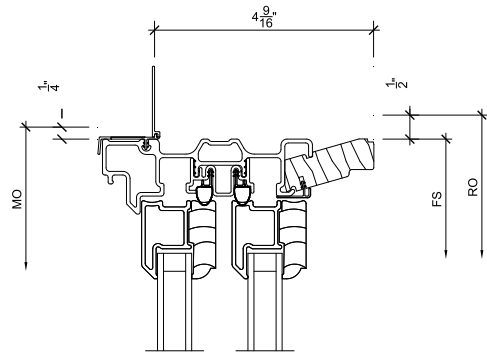

4
18

Head

SCALE: 3" = 1'-0"



PROJ/JOB: Kelleher / Elevate
 DIST/DEALER: ALCO PRODUCTS COMPANY INC-CIR
 DRAWN: MICHELLE REYNOLDS
 QUOTE#: 6DWAX6R PK VER: 0004.04.00

CREATED: 11/06/2023 REVISION:

SHEET
 18
 OF 21

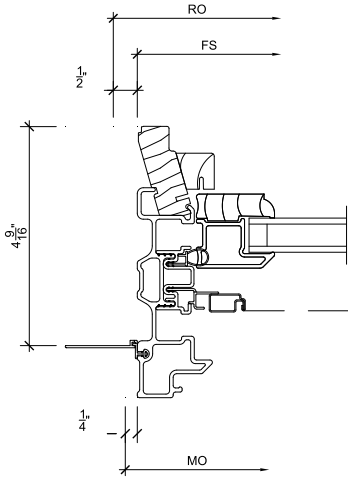

1
19

Jamb

SCALE: 3" = 1'-0"

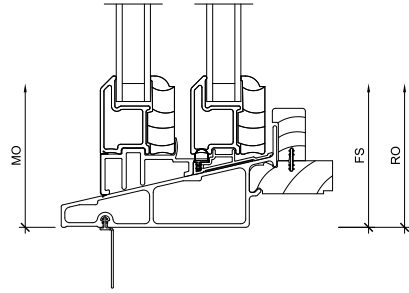

3
19

Sill

SCALE: 3" = 1'-0"

REVIEWED

By Dan.Bruechert at 3:35 pm, Nov 13, 2023

APPROVED
Montgomery County
Historic Preservation Commission

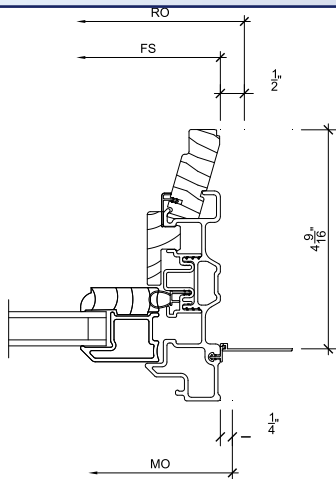

2
19

Jamb

SCALE: 3" = 1'-0"

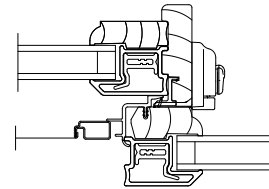

4
19

Meeting Stile

SCALE: 3" = 1'-0"



PROJ/JOB: Kelleher / Elevate
DIST/DEALER: ALCO PRODUCTS COMPANY INC-CIR
DRAWN: MICHELLE REYNOLDS
QUOTE#: 6DWAX6R PK VER: 0004.04.00

CREATED: 11/06/2023 REVISION:

SHEET
19
OF 21

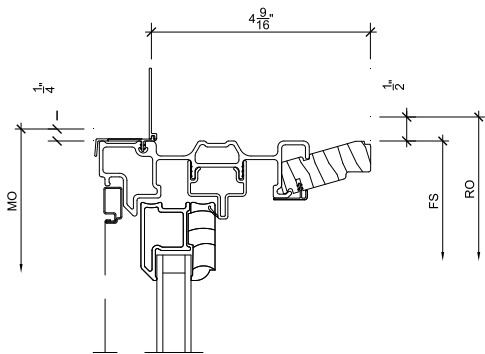

1
20

Head

SCALE: 3" = 1'-0"

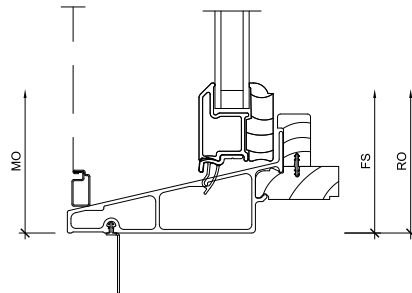

3
20

Sill

SCALE: 3" = 1'-0"

REVIEWED
By Dan.Bruechert at 3:35 pm, Nov 13, 2023

APPROVED
Montgomery County
Historic Preservation Commission
Robert H. [Signature]

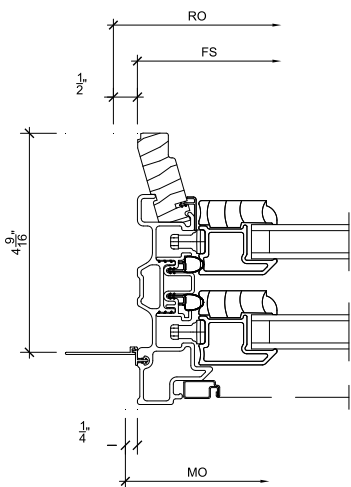

2
20

Jamb

SCALE: 3" = 1'-0"

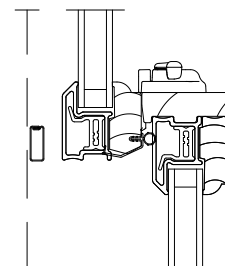

4
20

Check Rail

SCALE: 3" = 1'-0"



PROJ/JOB: Kelleher / Elevate
DIST/DEALER: ALCO PRODUCTS COMPANY INC-CIR
DRAWN: MICHELLE REYNOLDS
QUOTE#: 6DWAX6R PK VER: 0004.04.00

CREATED: 11/06/2023 REVISION:

SHEET
20
OF 21

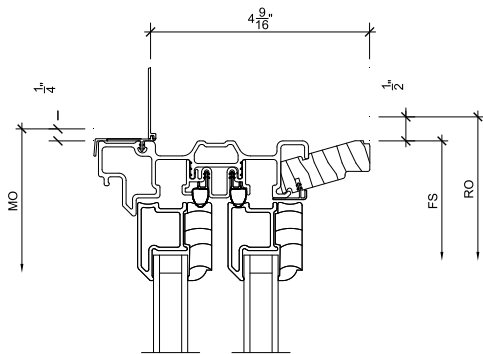

1
21

Head

SCALE: 3" = 1'-0"

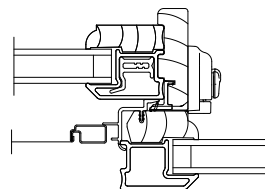

3
21

Meeting Stile

SCALE: 3" = 1'-0"

REVIEWED
By Dan.Bruechert at 3:35 pm, Nov 13, 2023

APPROVED
Montgomery County
Historic Preservation Commission
[Signature]

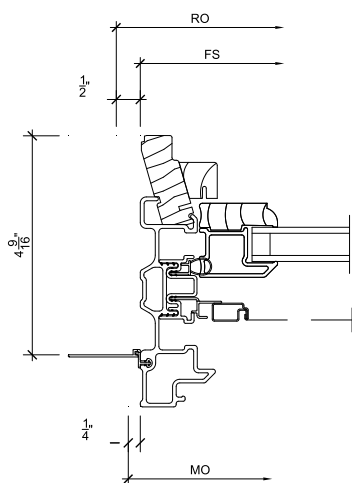

2
21

Jamb

SCALE: 3" = 1'-0"

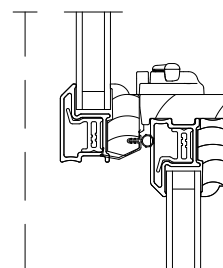

4
21

Check Rail

SCALE: 3" = 1'-0"



PROJ/JOB: Kelleher / Elevate
DIST/DEALER: ALCO PRODUCTS COMPANY INC-CIR
DRAWN: MICHELLE REYNOLDS
QUOTE#: 6DWAX6R PK VER: 0004.04.00

CREATED: 11/06/2023 REVISION:

SHEET
21
OF 21