



## HISTORIC PRESERVATION COMMISSION

Marc Elrich  
*County Executive*

Robert K. Sutton  
*Chairman*

Date: September 8, 2023

### MEMORANDUM

TO: Rabbiah Sabbakahn, Director  
Department of Permitting Services

FROM: Michael Kyne  
Historic Preservation Section  
Maryland-National Capital Park & Planning Commission

SUBJECT: Historic Area Work Permit #1040852 - Hardscape & Fence Construction

---

The Montgomery County Historic Preservation Commission (HPC) has reviewed the attached application for a Historic Area Work Permit (HAWP). This application was **Approved** at the September 6, 2023 HPC meeting.

The HPC staff has reviewed and stamped the attached construction drawings.

THE BUILDING PERMIT FOR THIS PROJECT SHALL BE ISSUED CONDITIONAL UPON ADHERENCE TO THE ABOVE APPROVED HAWP CONDITIONS AND MAY REQUIRE APPROVAL BY DPS OR ANOTHER LOCAL OFFICE BEFORE WORK CAN BEGIN.

Applicant: Marc & Leana Katz  
Address: 7 W. Kirke St., Chevy Chase

This HAWP approval is subject to the general condition that the applicant will obtain all other applicable Montgomery County or local government agency permits. After the issuance of these permits, the applicant must contact this Historic Preservation Office if any changes to the approved plan are made. Once work is complete the applicant will contact Michael Bruechert at 301.563.3408 or [dan.bruechert@montgomeryplanning.org](mailto:dan.bruechert@montgomeryplanning.org) to schedule a follow-up site visit.



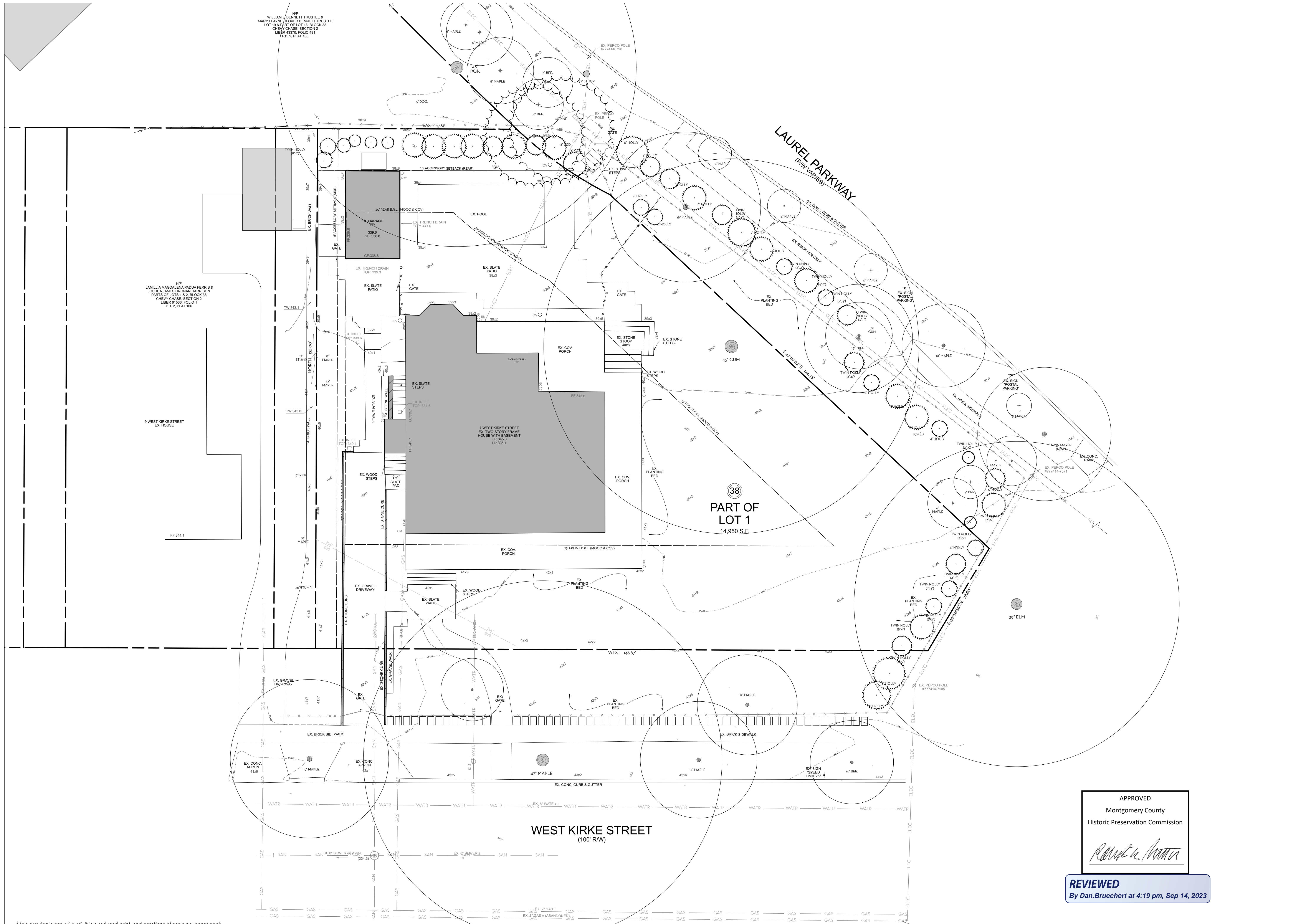

If this drawing is not 24" x 36", it is a reduced print, and notations of scale no longer apply.  
 If this drawing is 12" x 18", it is a 50% reduced print, and scaled dimensions need to be multiplied by a factor of 2.

NOTE: THE BASE PLAN IS DERIVED FROM A SURVEY GENERATED BY CAS ENGINEERING-DC, LLC. ON AUGUST 17, 2021. FIELD MEASUREMENTS TAKEN BY CHLA, AND GOOGLE EARTH AERIAL IMAGERY

APPROVED  
 Montgomery County  
 Historic Preservation Commission

*Robert A. [Signature]*

**REVIEWED**  
 By Dan.Bruechert at 4:19 pm, Sep 14, 2023

Consultants:

---

This drawing and the design shown hereon are the property of Campion Hruby Landscape Architects. The reproduction, copying or use of this drawing without written consent is prohibited and any infringement will be subject to legal action.

Project #: 22155  
**KATZ RESIDENCE**  
 7 W. Kirke Street  
 Chevy Chase, MD 20815  
 10 AUGUST 2023  
 PERMIT DOCUMENT

No.	Date	Description

Drawn By: MC Proj. Manager: LP  
 Approved By: KC

N  
 Scale: 1" = 10'-0"

EXISTING  
 CONDITIONS PLAN

**L101**



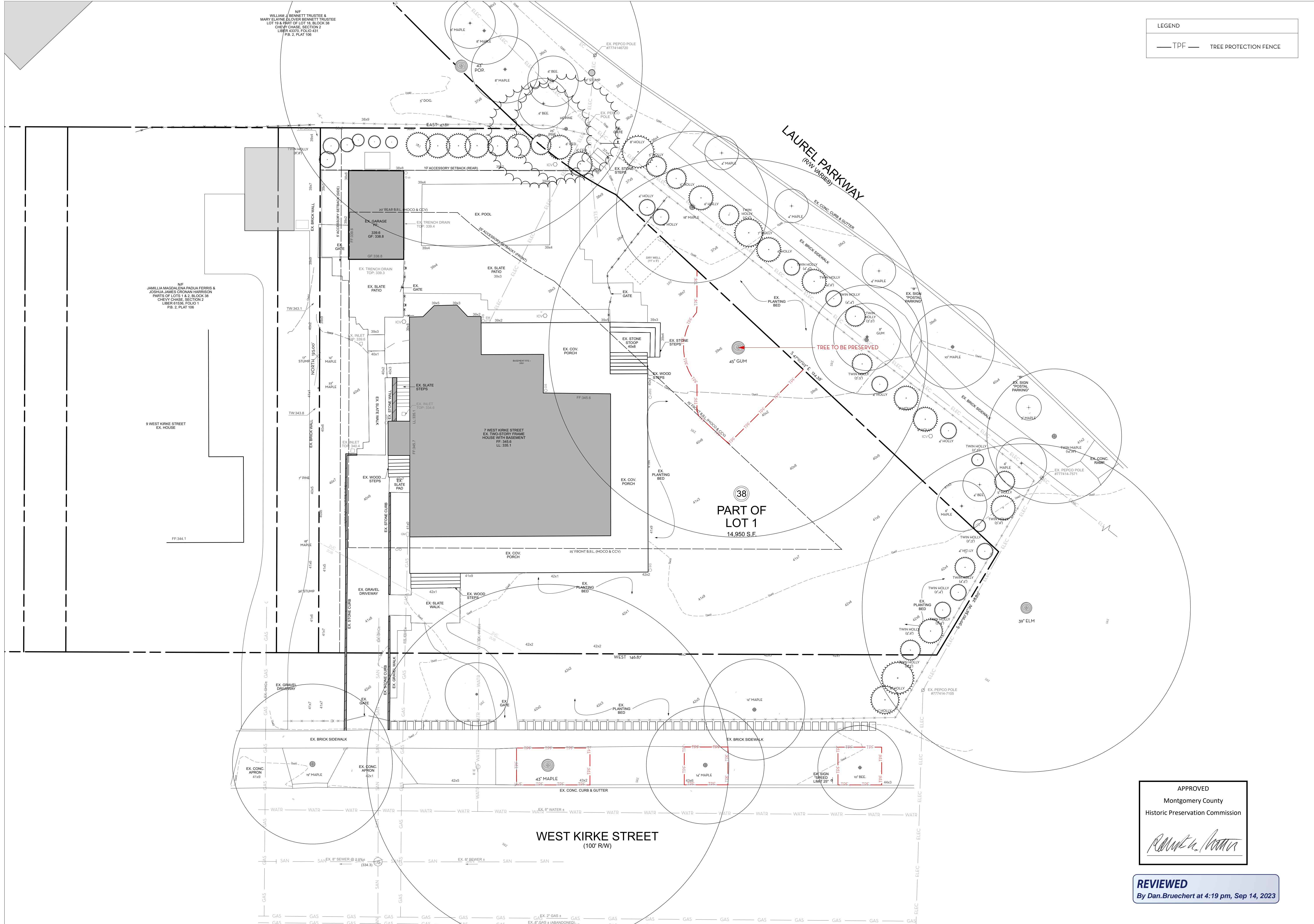

LEGEND  
 — TPF — TREE PROTECTION FENCE

CHLA

CAMPION/HRUBY

111 Cathedral Street, Suite 100 | Annapolis, MD 21401  
 O: 410.280.8850 campionhruby.com

Consultants:

This drawing and the design shown hereon are the property of Campion Hruby Landscape Architects. The reproduction, copying or use of this drawing without written consent is prohibited and any infringement will be subject to legal action.

Project #: 22155

# KATZ RESIDENCE

7 W. Kirke Street  
 Chevy Chase, MD 20815

10 AUGUST 2023

PERMIT DOCUMENT

No.	Date	Description

Drawn By: MC Proj. Manager: LP  
 Approved By: KC

Scale: 1" = 10'-0"

TREE PROTECTION PLAN

APPROVED  
 Montgomery County  
 Historic Preservation Commission

REVIEWED  
 By Dan.Bruechert at 4:19 pm, Sep 14, 2023

If this drawing is not 24" x 36", it is a reduced print, and notations of scale no longer apply.  
 If this drawings is 12' x 18", it is a 50% reduced print, and scaled dimensions need to be multiplied by a factor of 2.

NOTE: THE BASE PLAN IS DERIVED FROM A SURVEY GENERATED BY CAS ENGINEERING-DC, LLC, ON AUGUST 17, 2023. FIELD MEASUREMENTS TAKEN BY CHLA, AND GOOGLE EARTH AERIAL IMAGERY

# L102



Consultants:

The drawing and the design shown hereon are the property of Campion Hruby Landscape Architects. The reproduction, copying or use of this drawing without written consent is prohibited and any infringement will be subject to legal action.

Project #: 22155

## KATZ RESIDENCE

7 W. Kirke Street  
Chevy Chase, MD 20815

10 AUGUST 2023

PERMIT DOCUMENT

No.	Date	Description

Drawn By: MC Proj. Manager: LP  
Approved By: KC

N  
Scale: 1" = 10'-0"

DEMOLITION & REMOVALS

# LD100

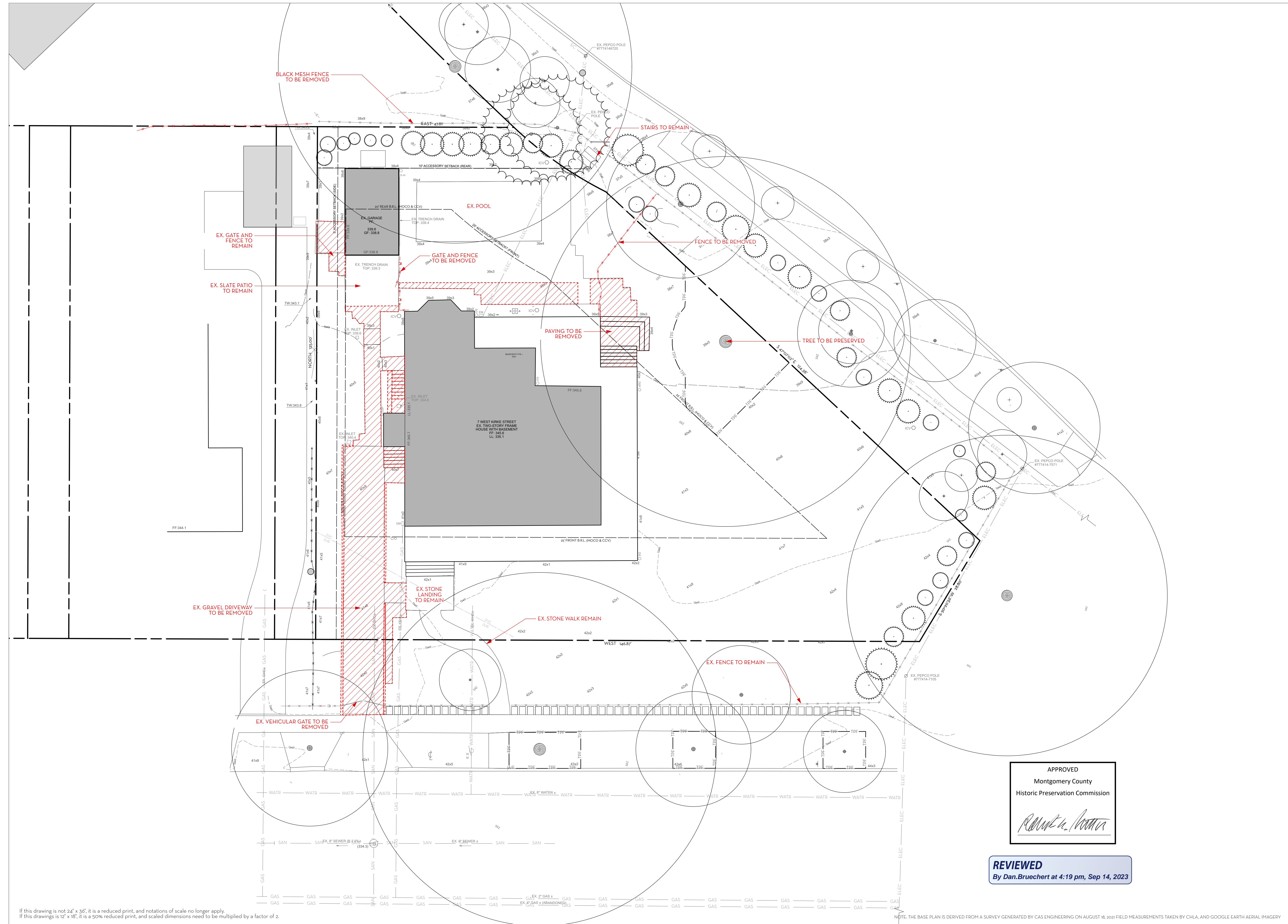

APPROVED  
Montgomery County  
Historic Preservation Commission

*R. Bruechert*

**REVIEWED**  
By Dan.Bruechert at 4:19 pm, Sep 14, 2023

If this drawing is not 24" x 36", it is a reduced print, and notations of scale no longer apply.  
If this drawing is 12" x 18", it is a 50% reduced print, and scaled dimensions need to be multiplied by a factor of 2.

NOTE: THE BASE PLAN IS DERIVED FROM A SURVEY GENERATED BY CAS ENGINEERING ON AUGUST 18, 2021 FIELD MEASUREMENTS TAKEN BY CHLA, AND GOOGLE EARTH AERIAL IMAGERY



NOTE: FENCE LAYOUT AND DETAILS TO BE FILED UNDER SEPARATE PERMIT



EXISTING RUBBLE STONE TO BE REUSED.

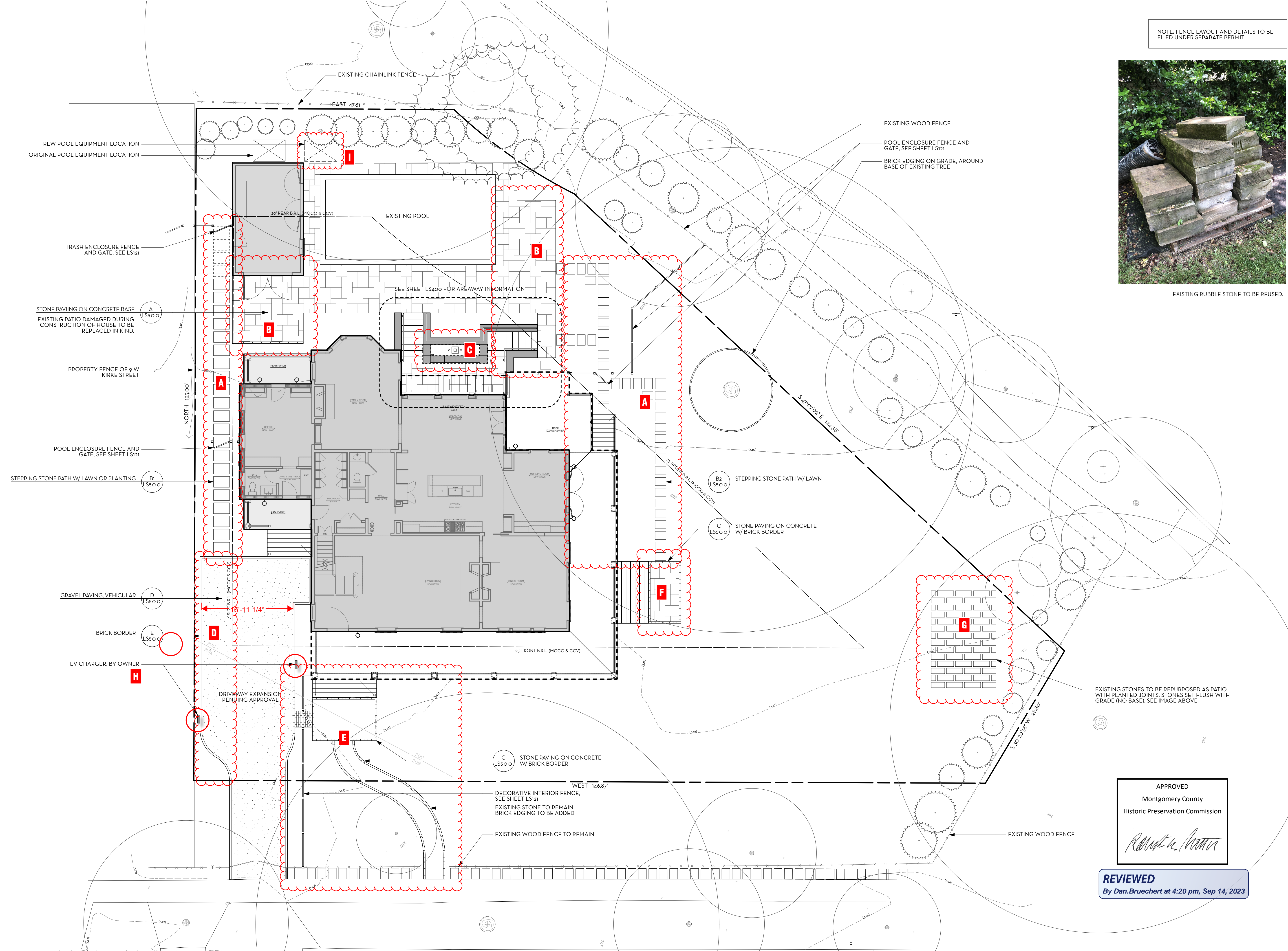

APPROVED  
Montgomery County  
Historic Preservation Commission

**REVIEWED**  
By Dan.Bruechert at 4:20 pm, Sep 14, 2023

**CHLA**

**CAMPION/HRUBY**

111 Cathedral Street, Suite 100 | Annapolis, MD 21401  
O: 410.280.8850 campionhruby.com

Consultants:

This drawing and the design shown hereon are the property of Campion Hruby Landscape Architects. The reproduction, copying or use of this drawing without written consent is prohibited and any infringement will be subject to legal action.

Project #: 22155

**KATZ RESIDENCE**

7 W. Kirke Street  
Chevy Chase, MD 20815

21 AUGUST 2023

PERMIT DOCUMENT

No.	Date	Description

Drawn By: MC Proj. Manager: LP  
Approved By: KC

N  
Scale: 1/8" = 1'-0"

HARDSCAPE PLAN

**LS100**

If this drawing is not 24" x 36", it is a reduced print, and notations of scale no longer apply.  
If this drawing is 12" x 18", it is a 50% reduced print, and scaled dimensions need to be multiplied by a factor of 2.

NOTE: THE BASE PLAN IS DERIVED FROM A SURVEY GENERATED BY CAS ENGINEERING-DC, LLC. ON AUGUST 17, 2021. FIELD MEASUREMENTS TAKEN BY CHLA, AND GOOGLE EARTH AERIAL IMAGERY



**GRADING NOTES:**

- INDEX ELEVATION IS 000, ALL OTHER SPOT ELEVATIONS ARE RELATIVE TO THIS INDEX.
- CONTRACTOR RESPONSIBLE FOR FIELD VERIFYING ALL SITE DATA/EXISTING GRADES PRIOR TO STARTING WORK.
- CONTRACTOR RESPONSIBLE FOR LOCATING ALL SITE UTILITIES.
- THE CONTRACTOR SHALL NOTIFY LANDSCAPE ARCHITECT IMMEDIATELY OF ANY DISCREPANCIES BETWEEN THE CONTRACT DRAWINGS AND THE SITE CONDITIONS.
- WRITTEN DIMENSIONS SHALL PREVAIL.

**LEGEND:**

TW TOP OF WALL  
 BW BOTTOM OF WALL  
 TS TOP OF STEP  
 BS BOTTOM OF STEP  
 TB TOP OF BENCH  
 TC TOP OF COPING  
 FFE FINISHED FLOOR ELEVATION  
 +20.0 PROPOSED GRADE  
 -L.O.D. LIMIT OF DISTURBANCE  
 -24 PROPOSED CONTOURS  
 -24 EXISTING CONTOURS  
 DIRECTION OF FLOW  
 DRAIN LINE

**NOTE:**

- CONTRACTOR TO PROVIDE MOCKUP OF WALL LAYOUT IN FIELD FOR LANDSCAPE ARCHITECT APPROVAL PRIOR TO THE POURING OF CONCRETE WALLS.
- IN THE INSTANCE OF ANY INCONSISTENCIES BETWEEN DRAWINGS AND FIELD CONDITIONS, CONTRACTOR IS TO NOTIFY LANDSCAPE ARCHITECT IMMEDIATELY.
- CONTRACTOR TO VERIFY SIZE OF VENEER PRIOR TO CONSTRUCTION.

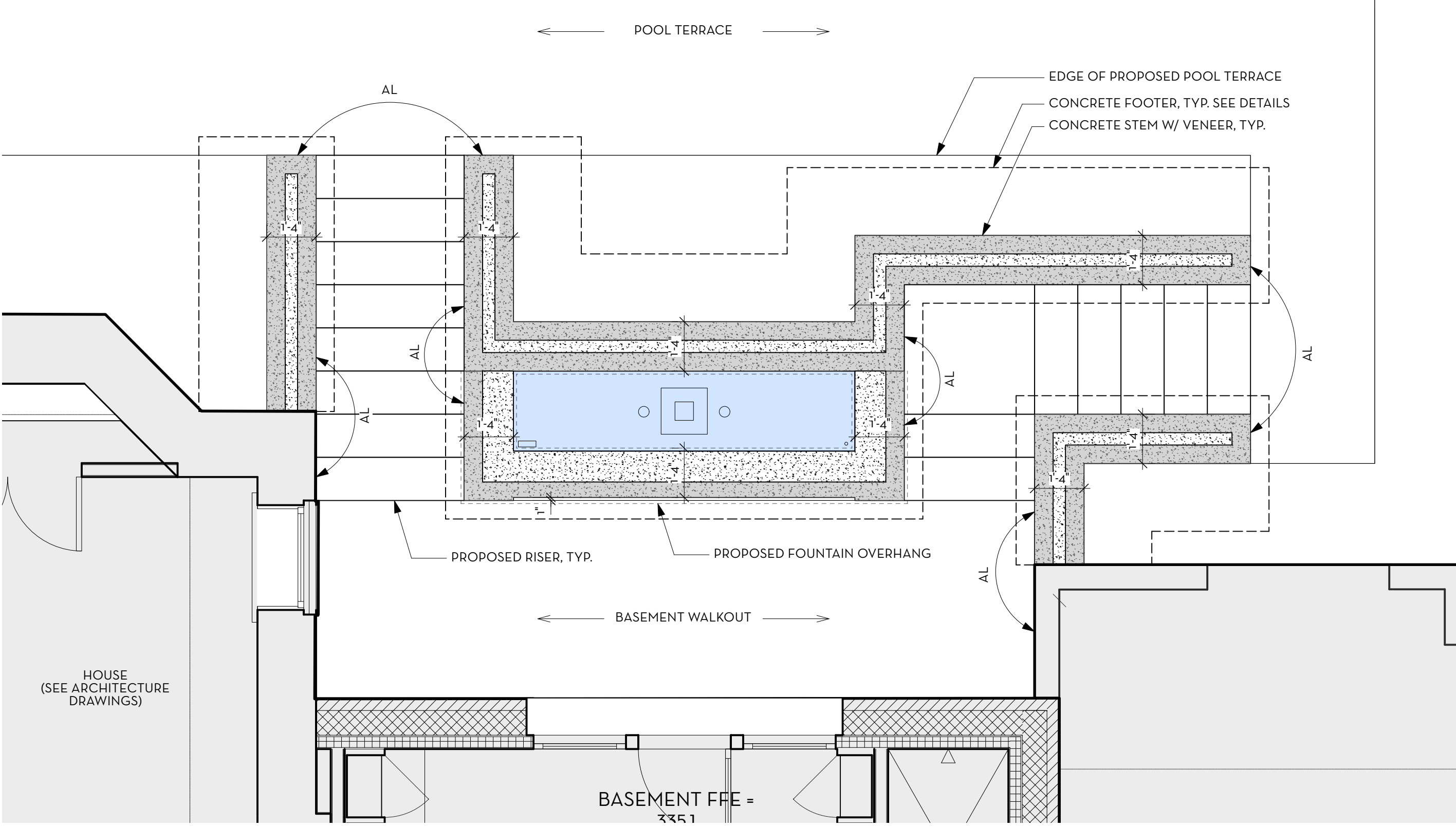
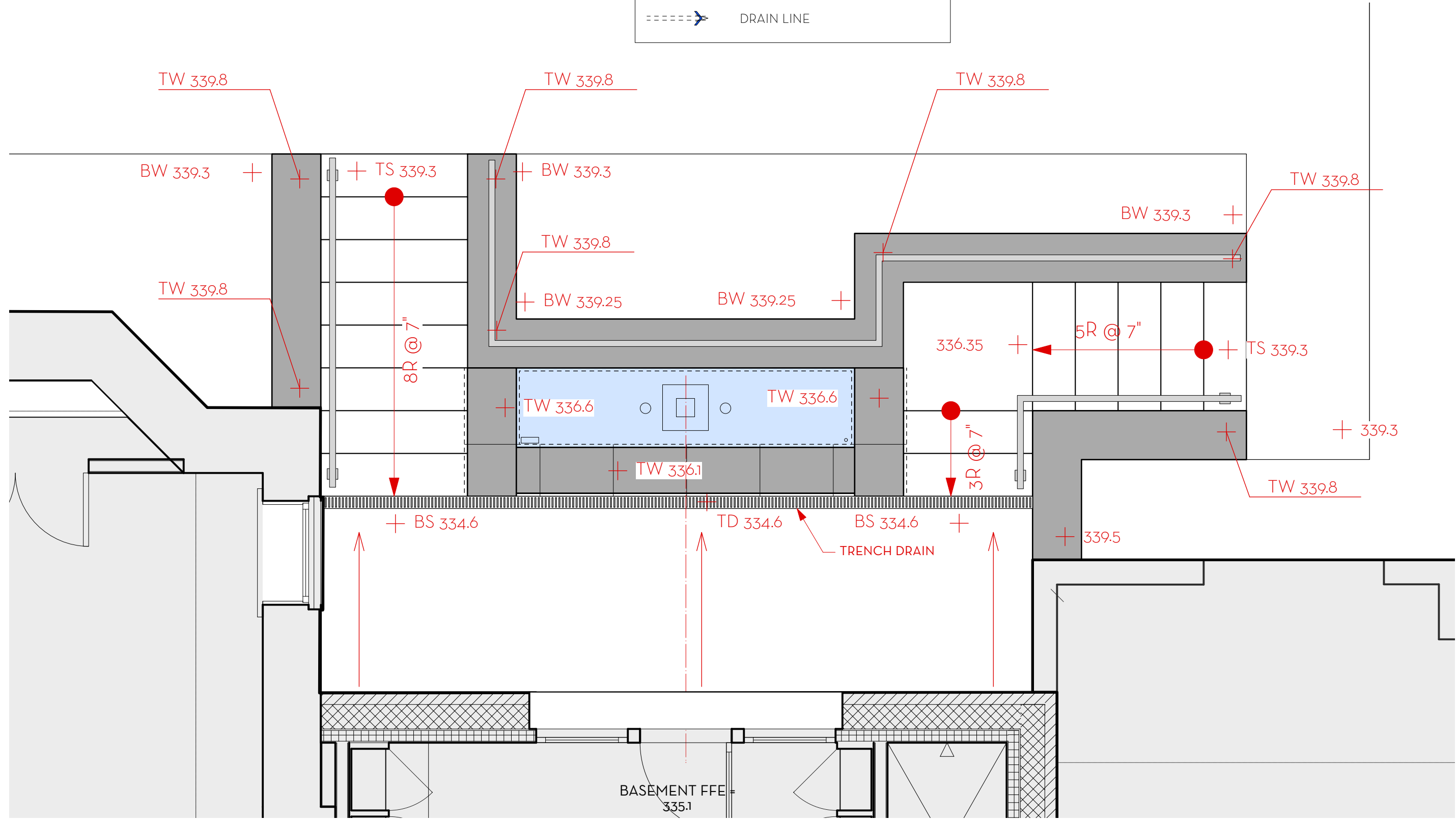

A AREAWAY ENLARGEMENT - GRADING PLAN  
 Scale: 3/8" = 1'-0"

B AREAWAY ENLARGEMENT - WALL LAYOUT PLAN  
 Scale: 3/8" = 1'-0"

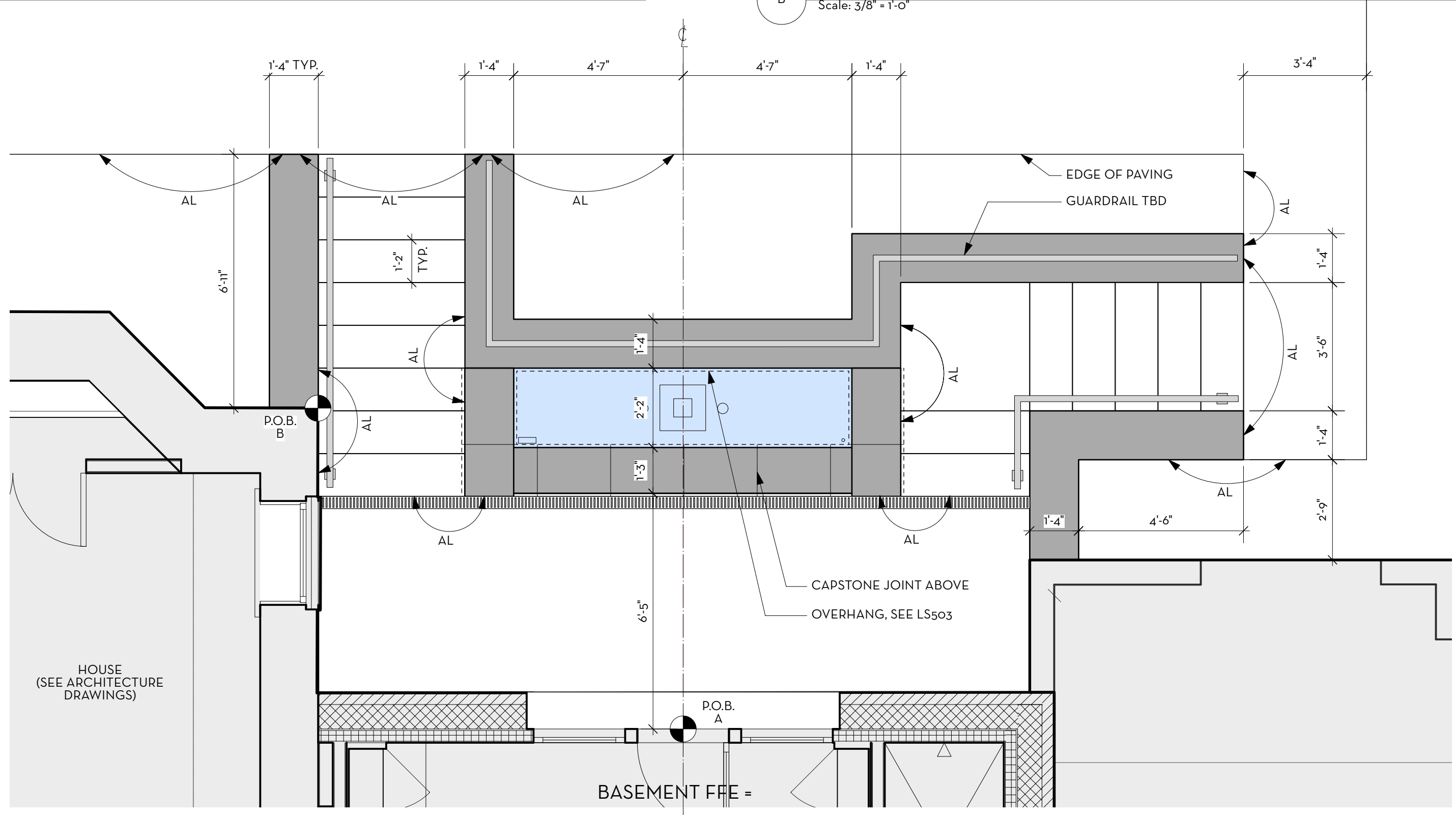

C AREAWAY ENLARGEMENT - LAYOUT PLAN  
 Scale: 3/8" = 1'-0"

**LAYOUT NOTES:**

- THE CONTRACTOR IS RESPONSIBLE FOR FIELD VERIFYING ALL SITE DATA.
- THE CONTRACTOR IS RESPONSIBLE FOR LOCATING ALL SITE UTILITIES.
- THE CONTRACTOR SHALL NOTIFY LANDSCAPE ARCHITECT IMMEDIATELY OF ANY DISCREPANCIES BETWEEN THE CONTRACT DRAWINGS AND THE SITE CONDITIONS.
- THE CONTRACTOR IS RESPONSIBLE FOR PROTECTING ALL TREES DESIGNATED TO REMAIN (WITHIN DRIPLINE) FROM HEAVY EQUIPMENT COMPACTION, STOCKPILING, ETC.
- THE CONTRACTOR SHALL NOTIFY "MISS UTILITY" AT 1-800-257-7777 AT LEAST FIVE DAYS BEFORE STARTING WORK.
- THE CONTRACTOR SHALL OBTAIN THE LANDSCAPE ARCHITECT'S APPROVAL OF ALL STAKED OUT LAYOUT BEFORE PROCEEDING WITH CONSTRUCTION.
- WRITTEN DIMENSIONS SHALL PREVAIL.
- ALL DIMENSION LINES ARE TAKEN OFF THE REFERENCE LINE AT 90 DEGREE ANGLES.

**LEGEND:**

TYP. TYPICAL  
 R RADIUS  
 CL CENTERLINE  
 P.O.B. POINT OF BEGINNING  
 ALIGN

APPROVED  
 Montgomery County  
 Historic Preservation Commission  
*[Signature]*

**REVIEWED**  
 By Dan.Bruechert at 4:20 pm, Sep 14, 2023

If this drawing is not 24" x 36", it is a reduced print, and notations of scale no longer apply.  
 If this drawings is 12" x 18", it is a 50% reduced print, and scaled dimensions need to be multiplied by a factor of 2.

Consultants:

Project #: 22155

**KATZ RESIDENCE**  
 7 W. Kirke Street  
 Chevy Chase, MD 20815

10 AUGUST 2023

PERMIT DOCUMENT

No.	Date	Description

Drawn By: MC Proj. Manager: LP  
 Approved By: KC

N  
 Scale: AS SHOWN

PLAN ENLARGEMENTS - AREAWAY

**LS400**

This drawing and the design shown hereon are the property of Campion Hruby Landscape Architects. The reproduction, copying or use of this drawing without written consent is prohibited and any infringement will be subject to legal action.



Consultants:

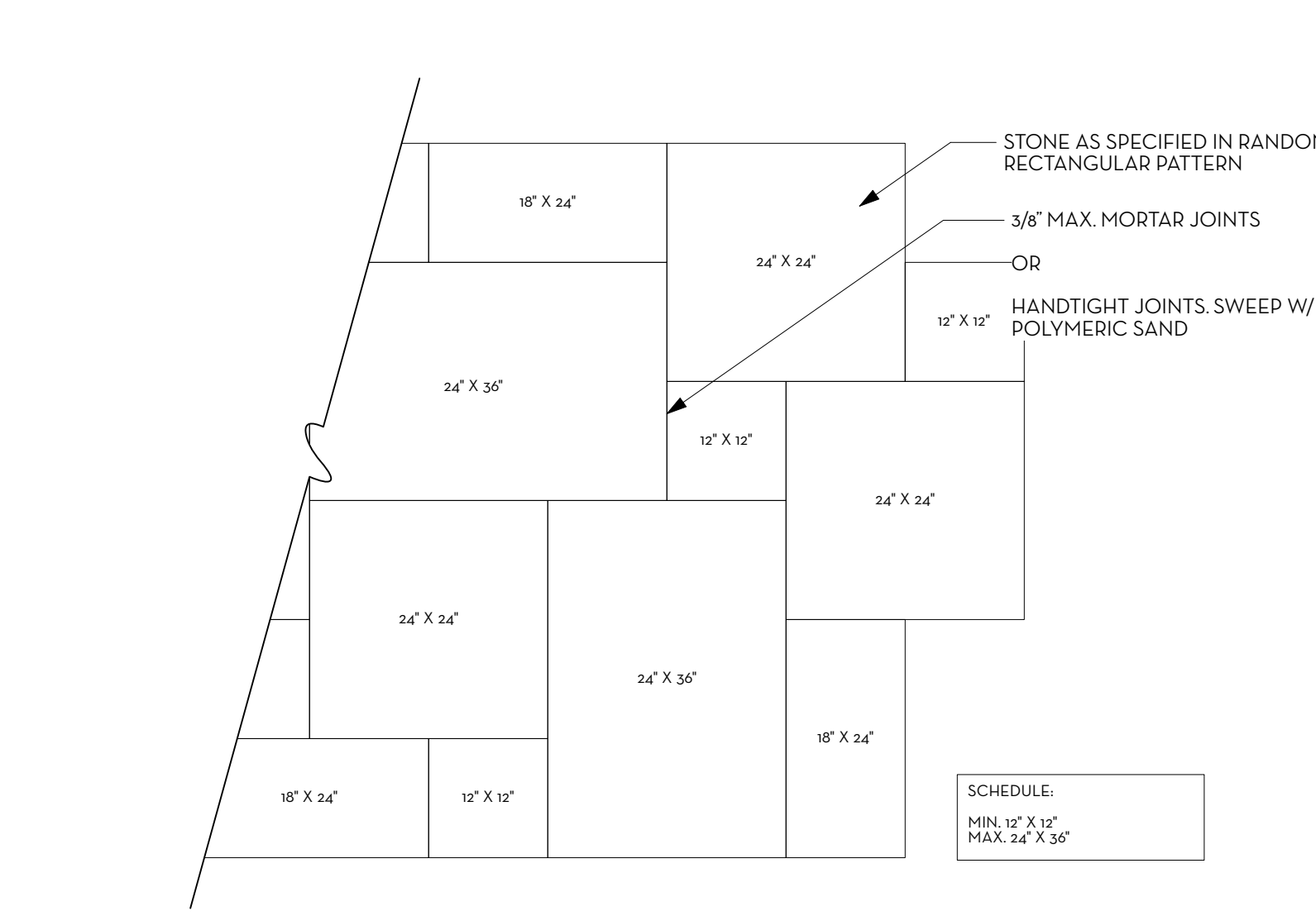

PLAN VIEW  
Scale: 3/4" = 1'-0"

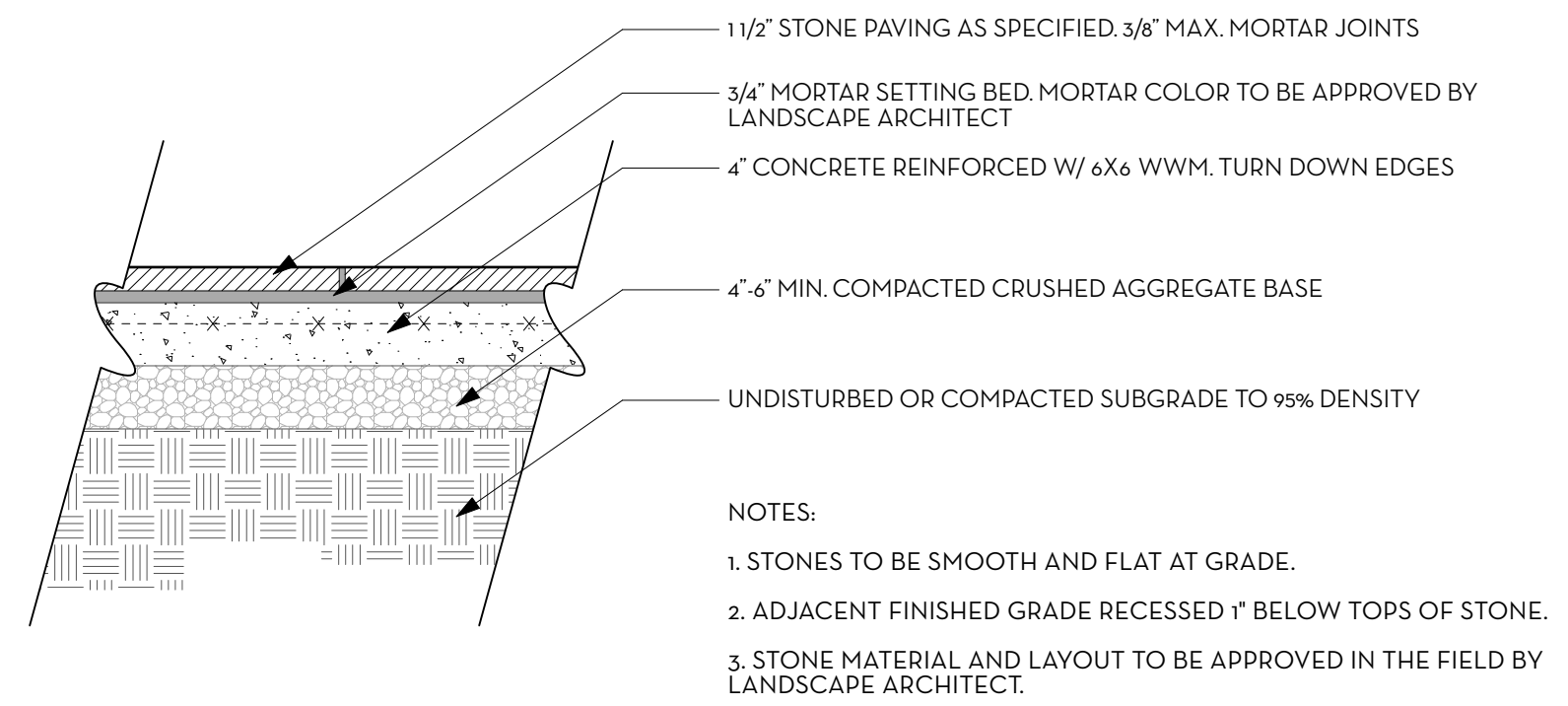

A STONE PAVING ON CONCRETE BASE - MORTAR  
Scale: 1" = 1'-0"

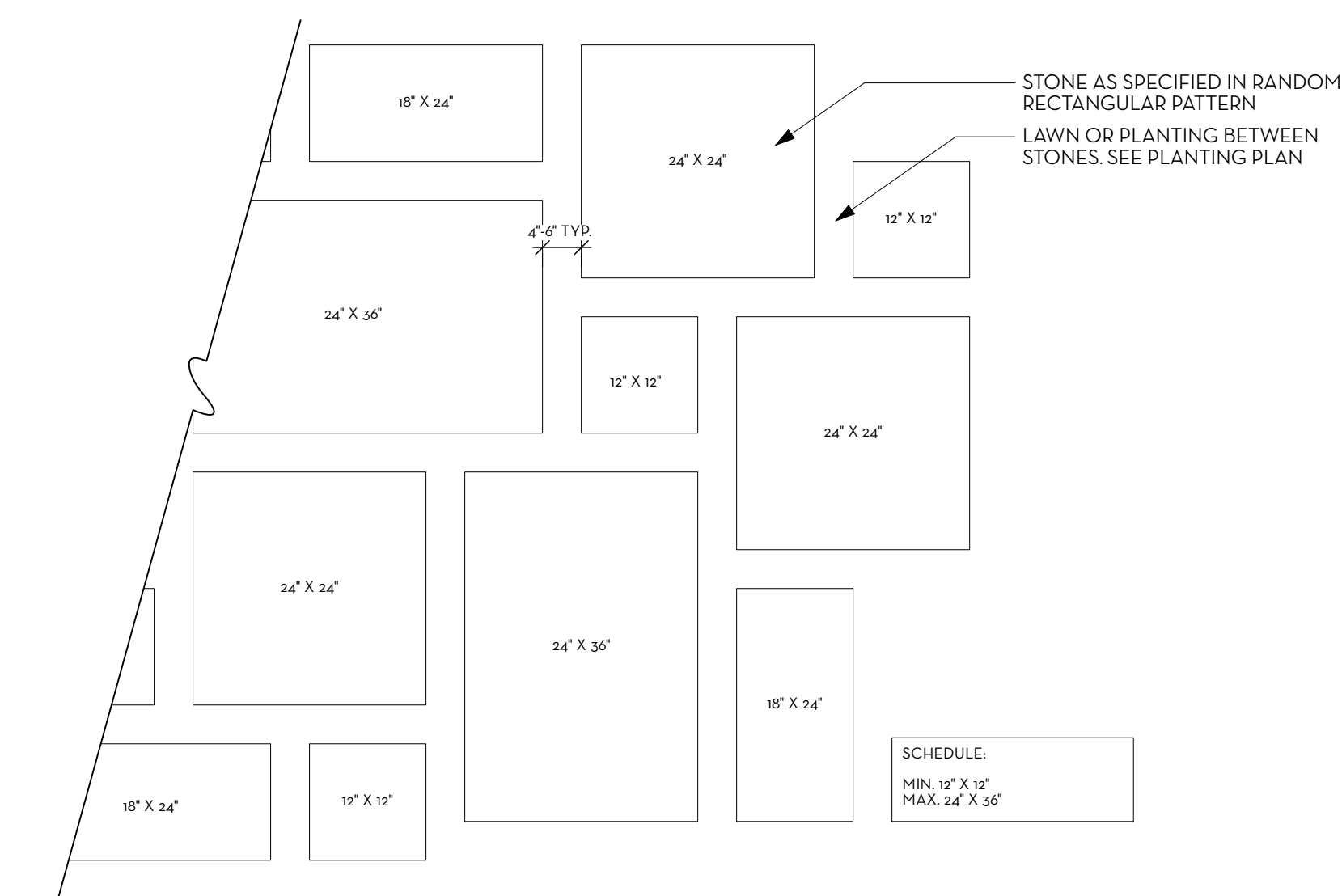

PLAN VIEW  
Scale: 3/4" = 1'-0"

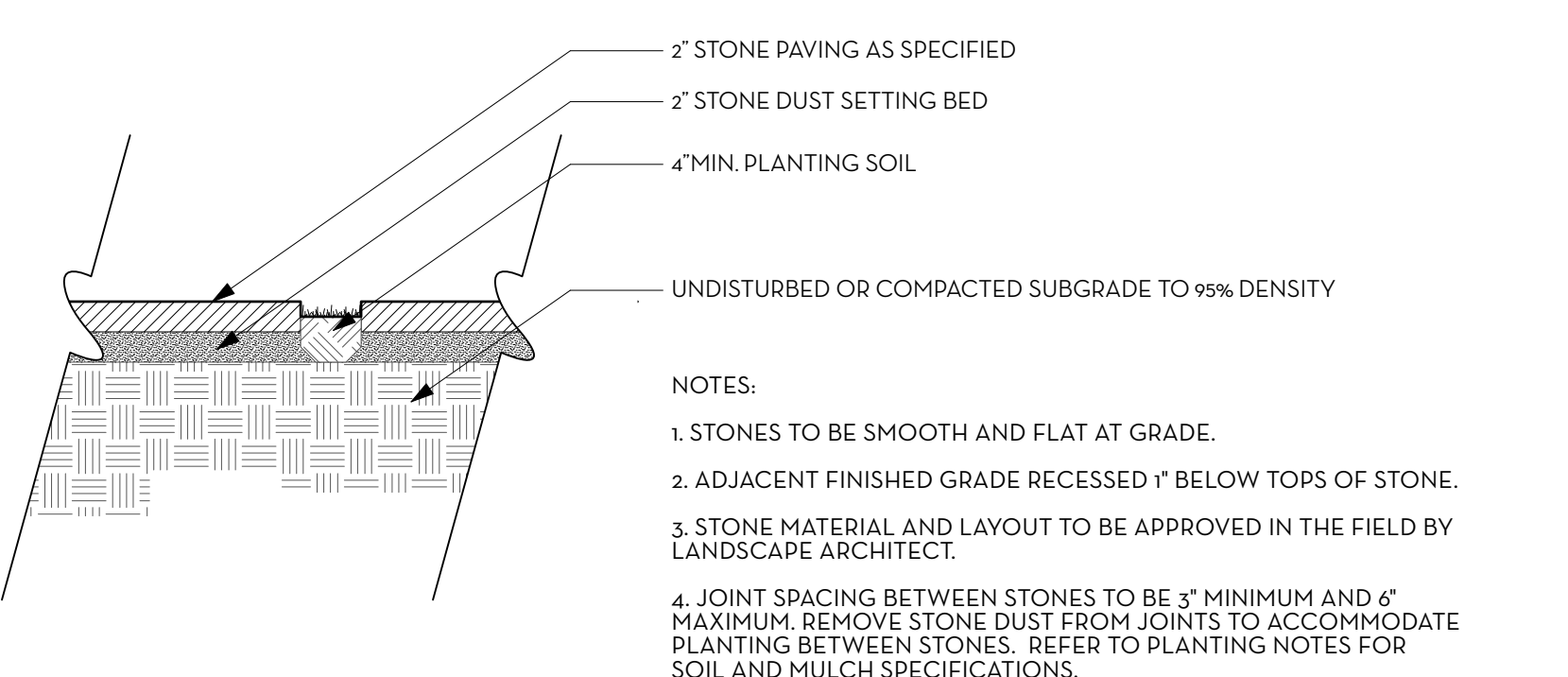

B1 STEPPING STONE PATH W/ PLANTING OR LAWN  
Scale: 1" = 1'-0"

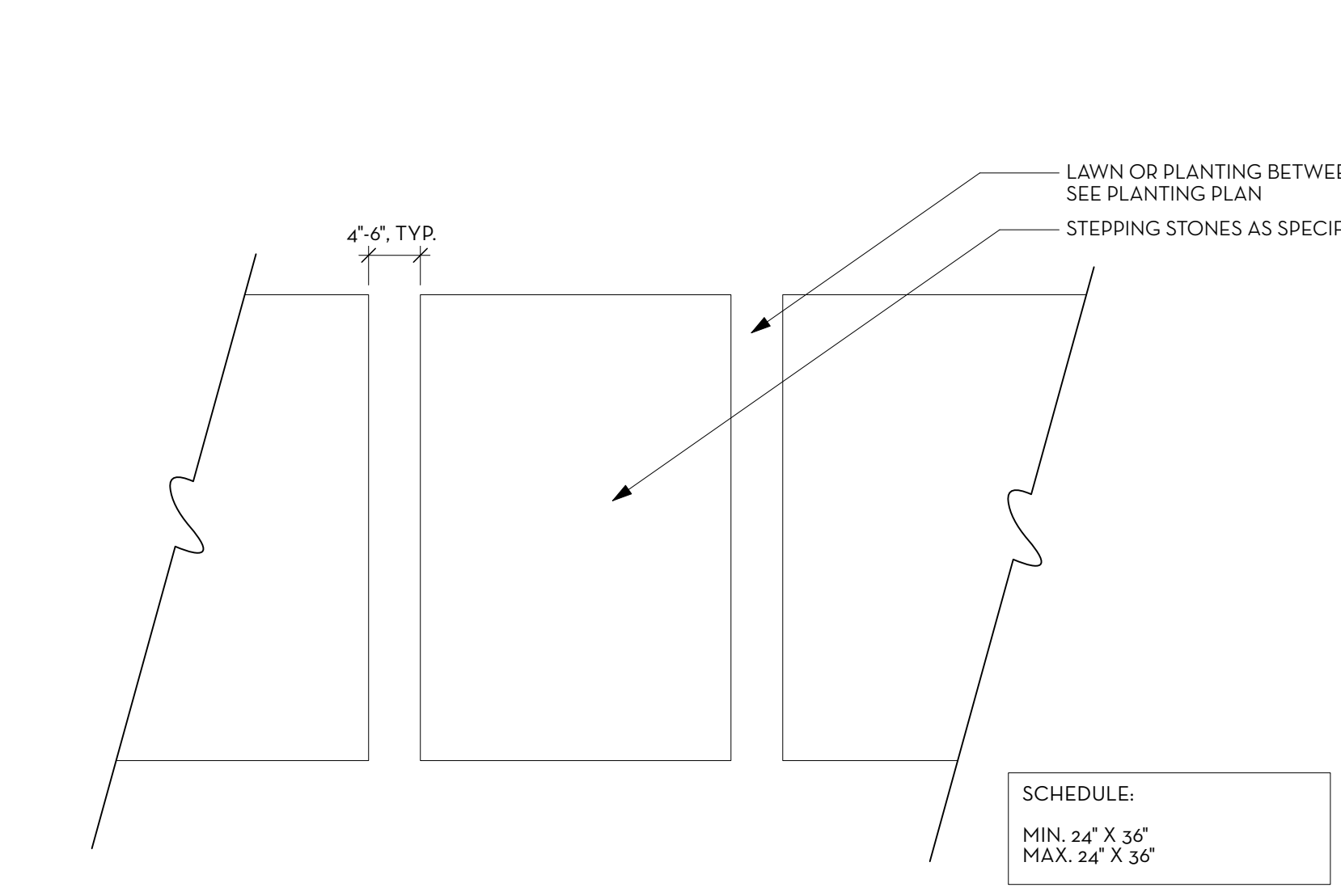

PLAN VIEW  
Scale: 1" = 1'-0"

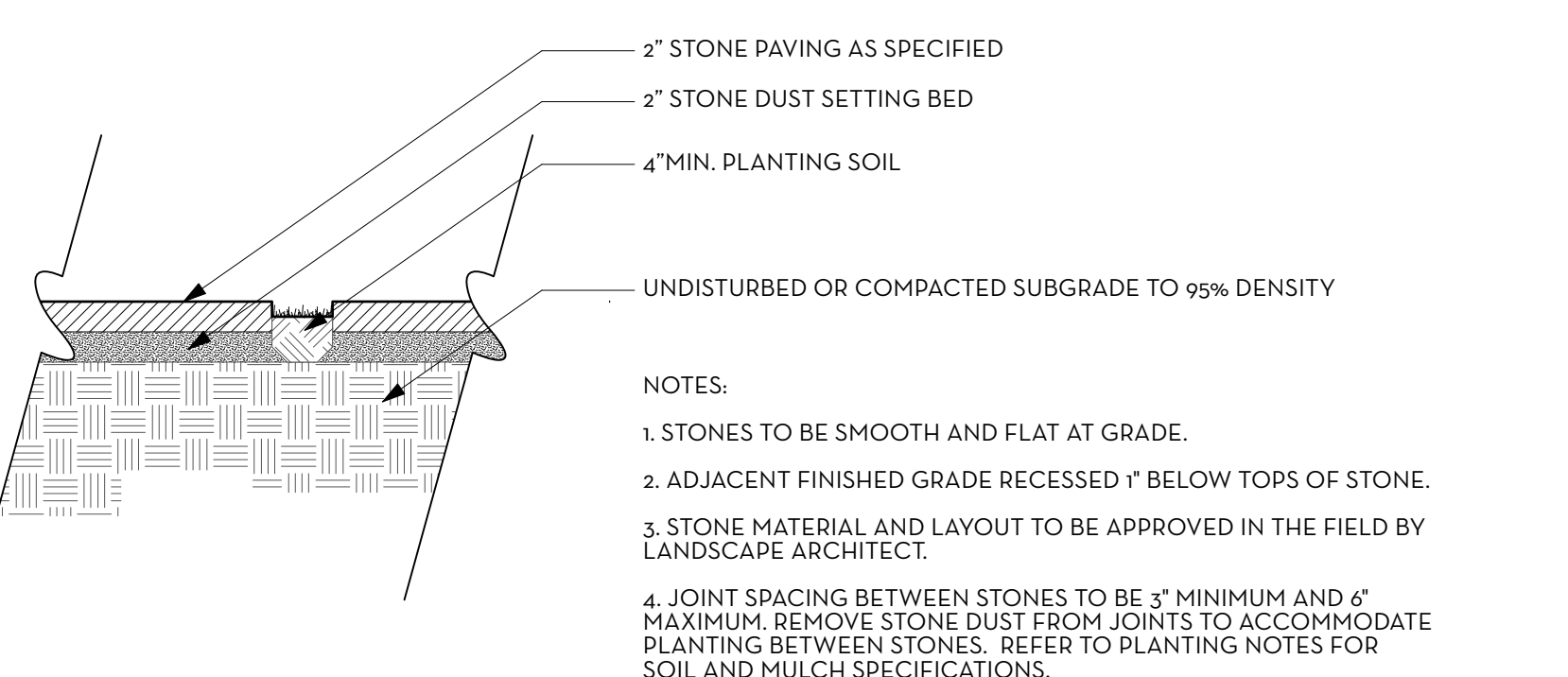

B2 STEPPING STONE PATH W/ PLANTING OR LAWN  
Scale: 1" = 1'-0"

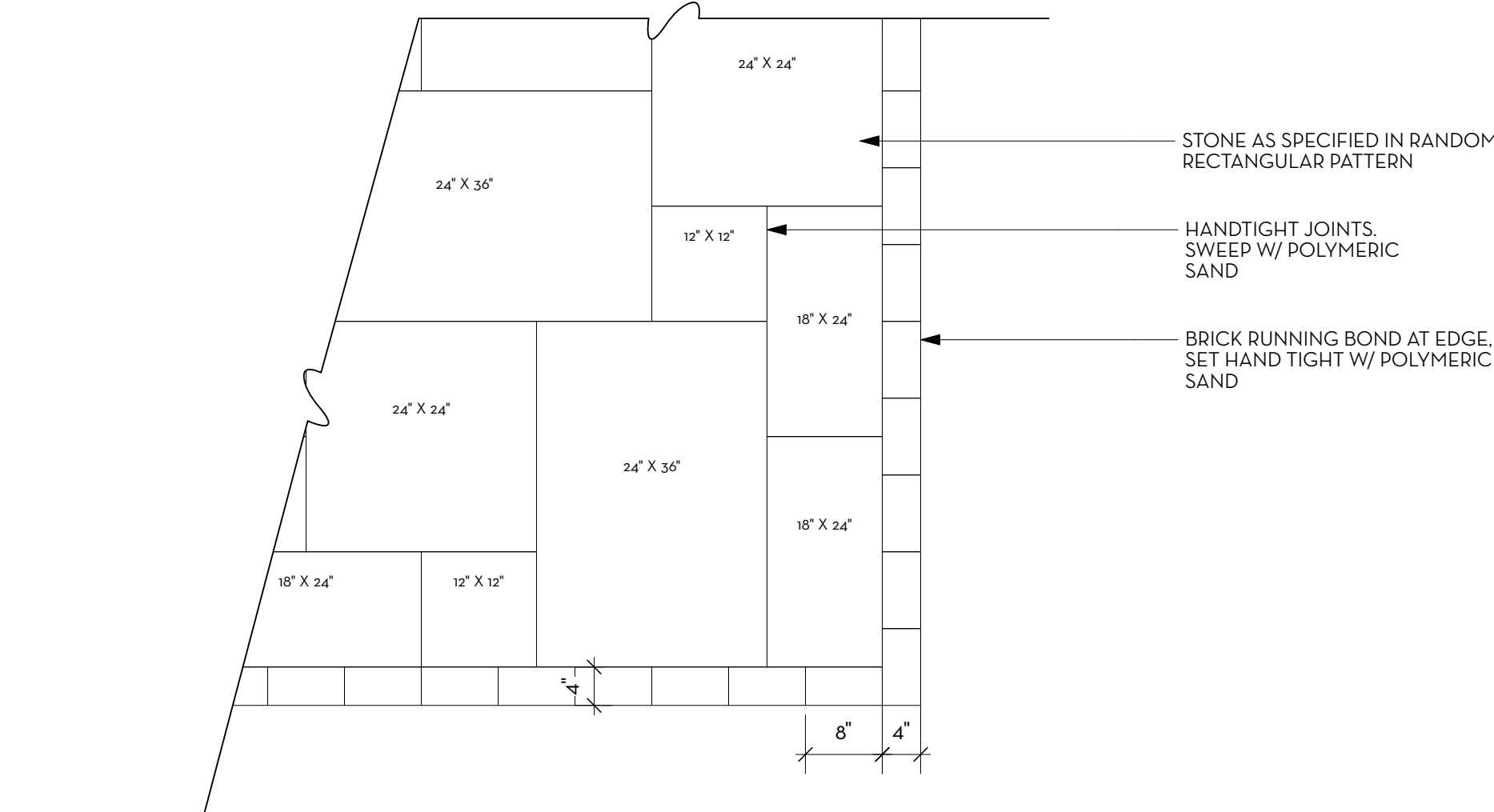

PLAN VIEW  
Scale: 3/4" = 1'-0"

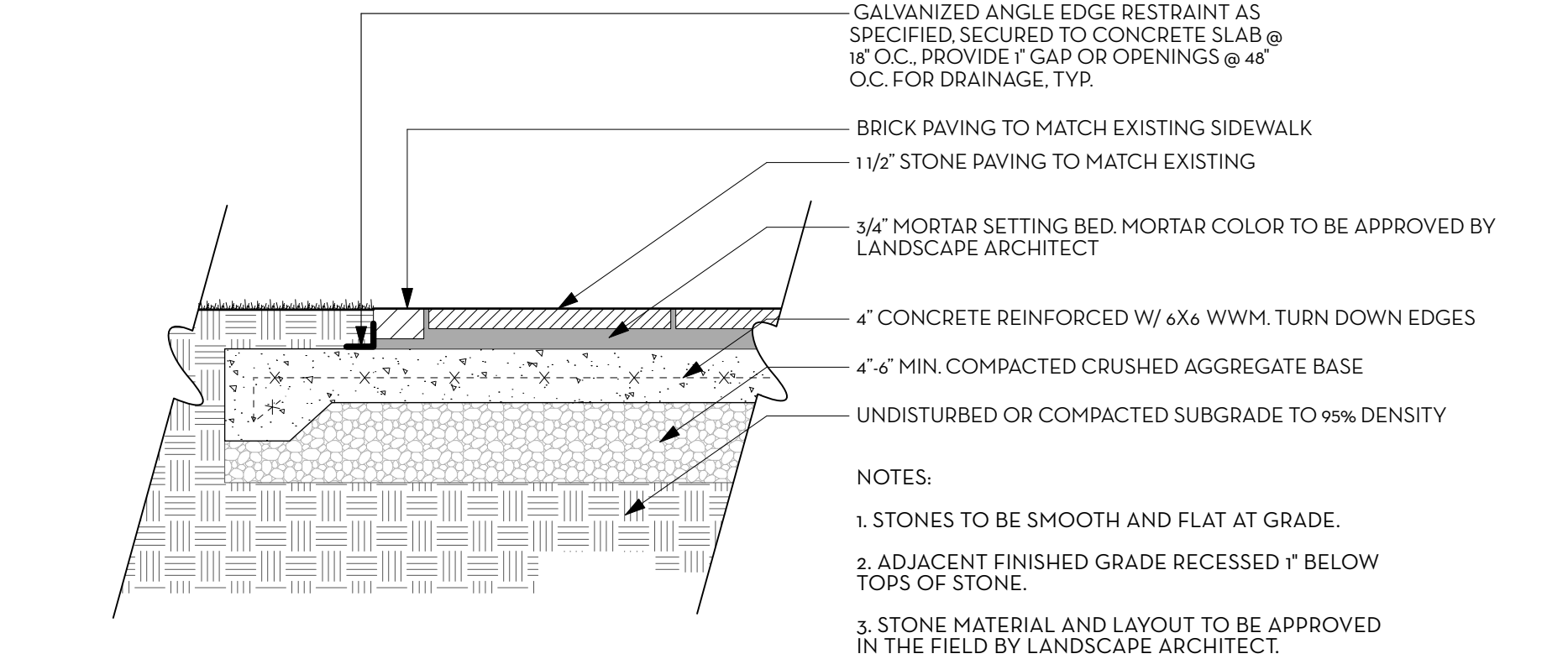

C STONE PAVING ON CONCRETE W/ BRICK BORDER  
Scale: 1" = 1'-0"

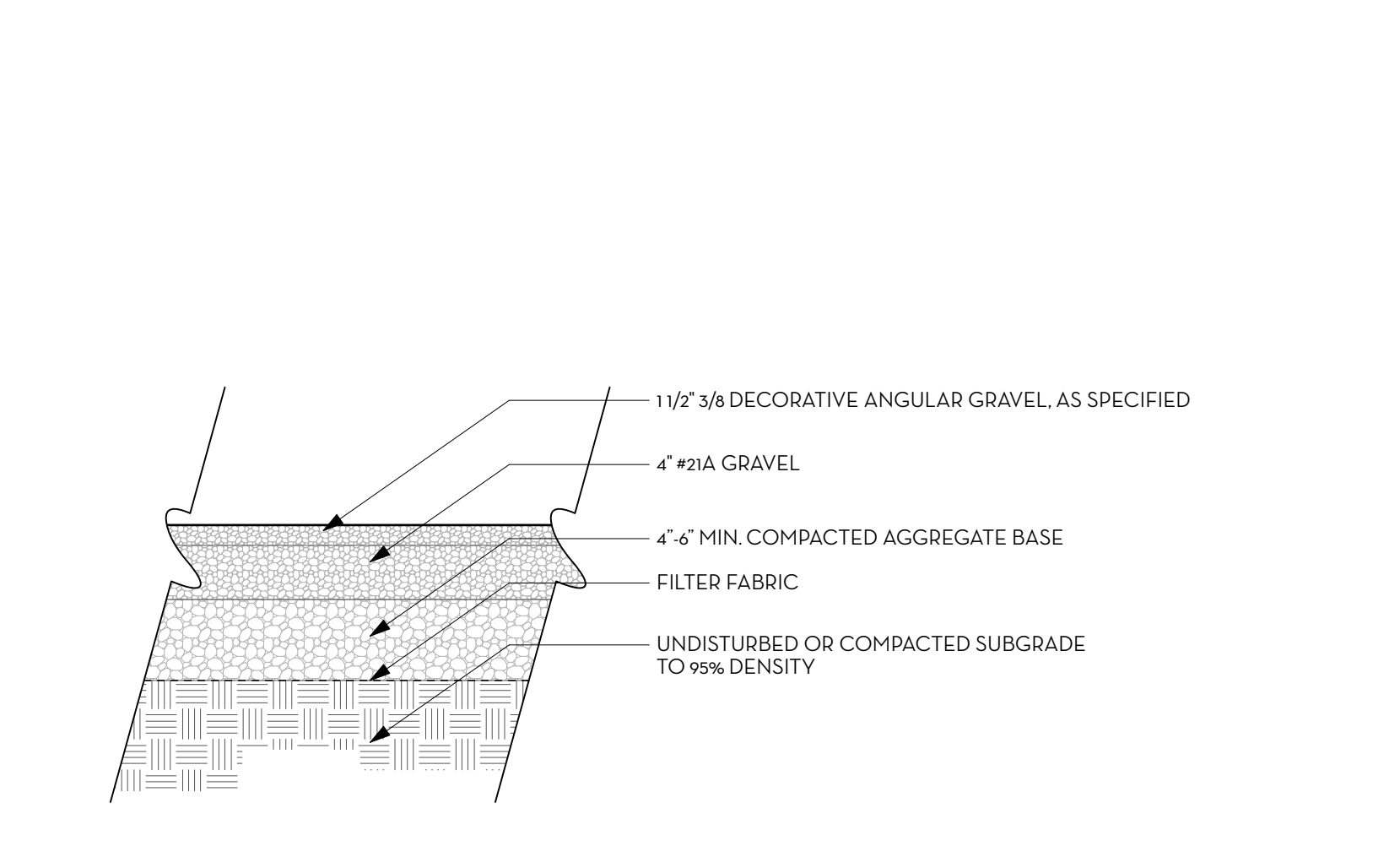

D GRAVEL PAVING - VEHICULAR  
Scale: 1" = 1'-0"

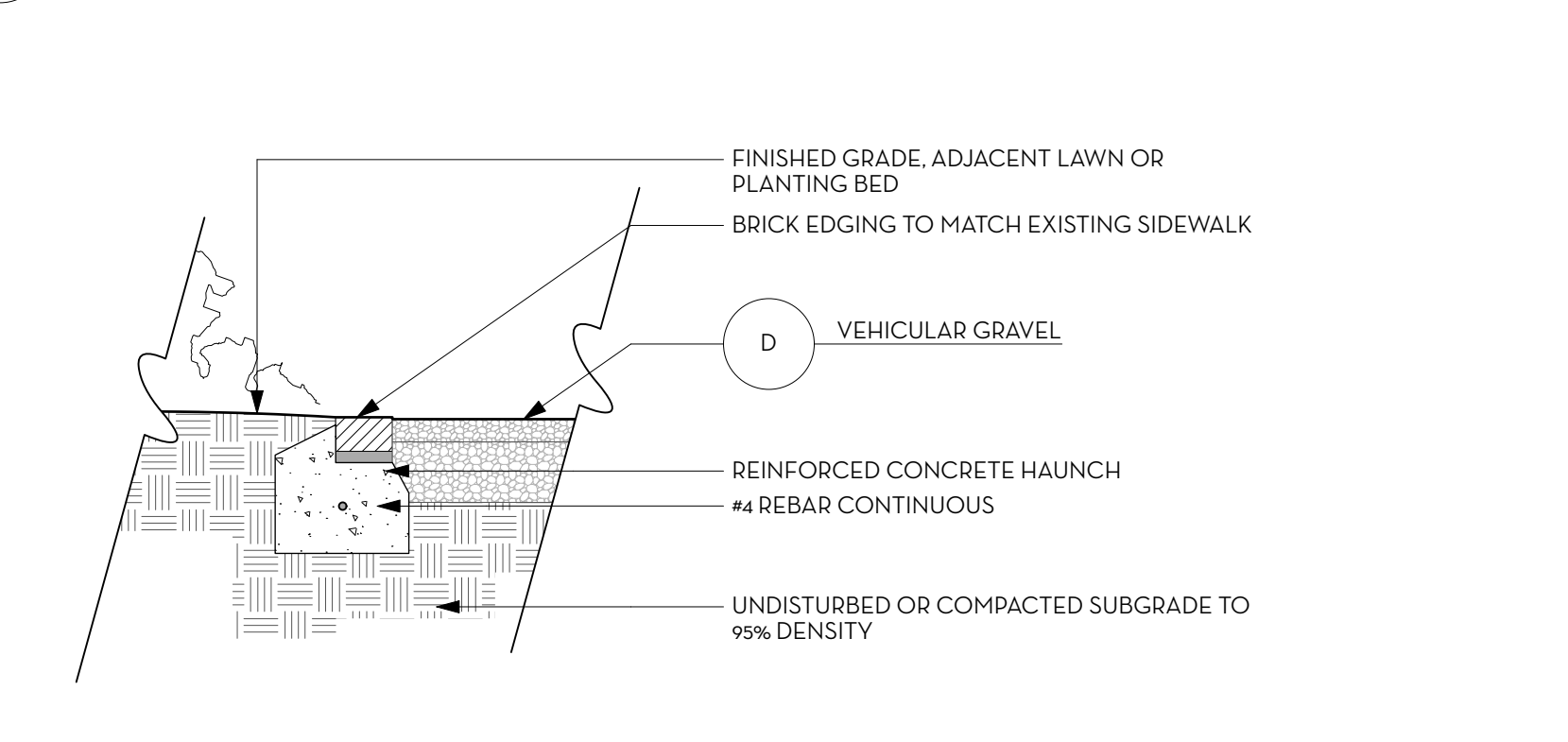

E BRICK BORDER  
Scale: 1" = 1'-0"

APPROVED  
Montgomery County  
Historic Preservation Commission

REVIEWED  
By Dan.Bruechert at 4:20 pm, Sep 14, 2023

This drawing and the design shown hereon are the property of Campion Hruby Landscape Architects. The reproduction, copying or use of this drawing without written consent is prohibited and any infringement will be subject to legal action.

Project #: 22155

## KATZ RESIDENCE

7 W. Kirke Street  
Chevy Chase, MD 20815

10 AUGUST 2023

### PERMIT DOCUMENT

No.	Date	Description

Drawn By: MC Proj. Manager: LP  
Approved By: KC

Scale: AS SHOWN

### HARDSCAPE DETAILS - PAVING

# LS500

If this drawing is not 24' x 36', it is a reduced print, and notations of scale no longer apply.  
 If this drawings is 12' x 18', it is a 50% reduced print, and scaled dimensions need to be multiplied by a factor of 2.



NOTE:  
 1. ALL FOOTING SIZES AND REINFORCEMENT TO BE APPROVED BY STRUCTURAL ENGINEER PRIOR TO CONSTRUCTION.  
 2. CONTRACTOR TO VERIFY SIZE OF VENEER PRIOR TO CONSTRUCTION.

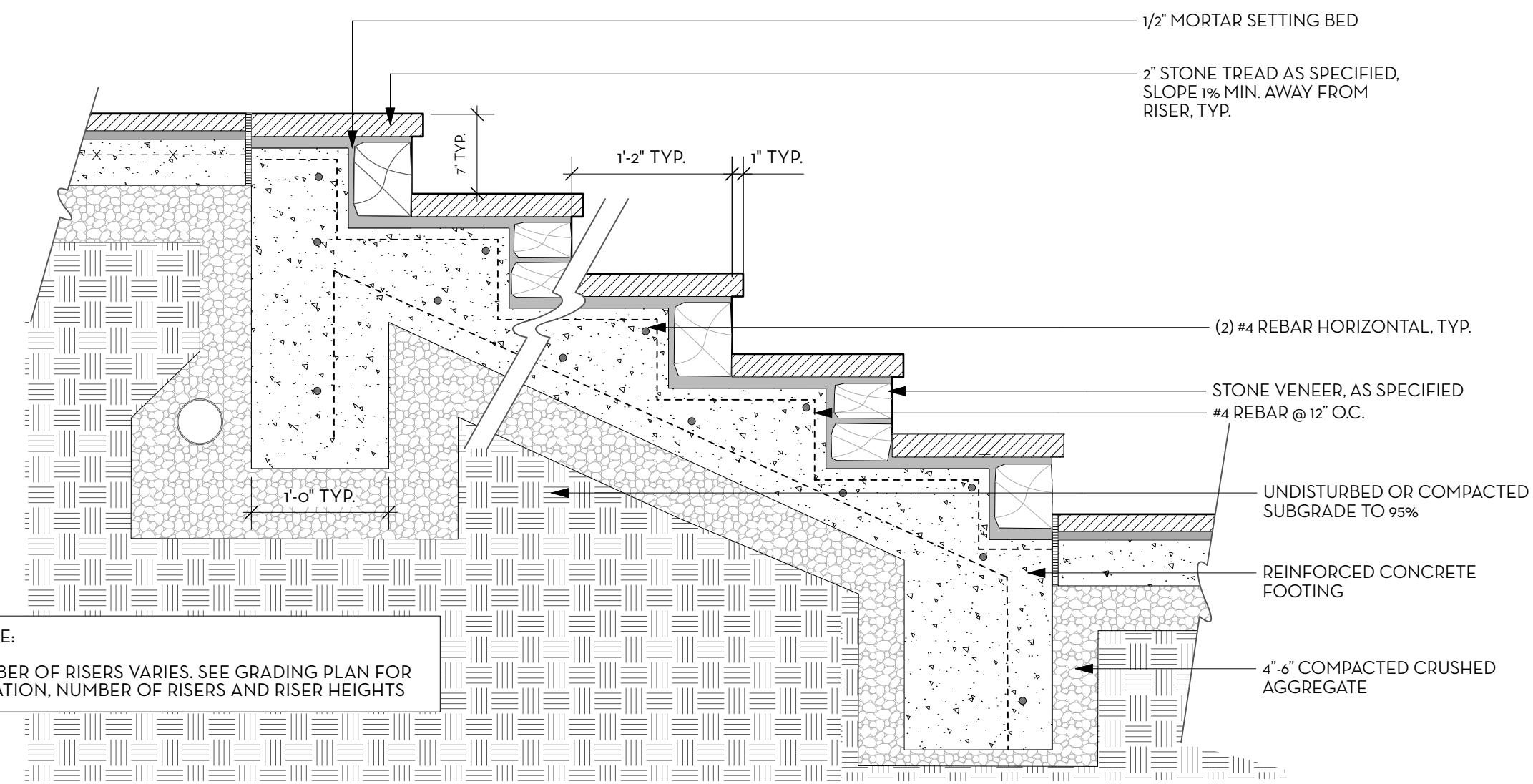

\*NOTE:  
 NUMBER OF RISERS VARIES. SEE GRADING PLAN FOR LOCATION, NUMBER OF RISERS AND RISER HEIGHTS

A STONE STEPS WITH STONE RISERS  
 Scale: 1" = 1'-0"

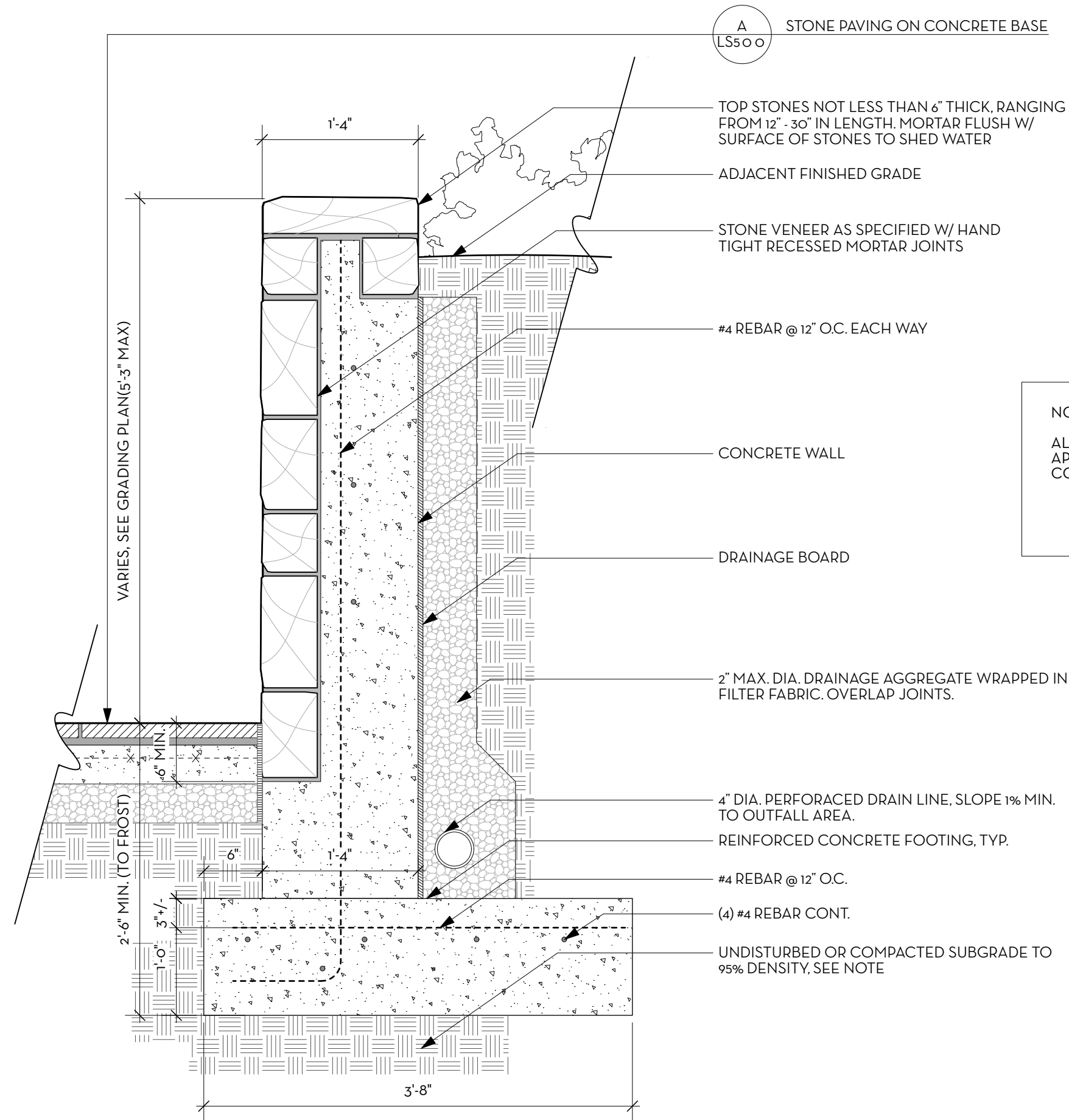

NOTE:  
 ALL FOOTING SIZES AND REINFORCEMENT TO BE APPROVED BY STRUCTURAL ENGINEER PRIOR TO CONSTRUCTION.

B1 STONE RETAINING WALL - CONDITION A  
 Scale: 1" = 1'-0"

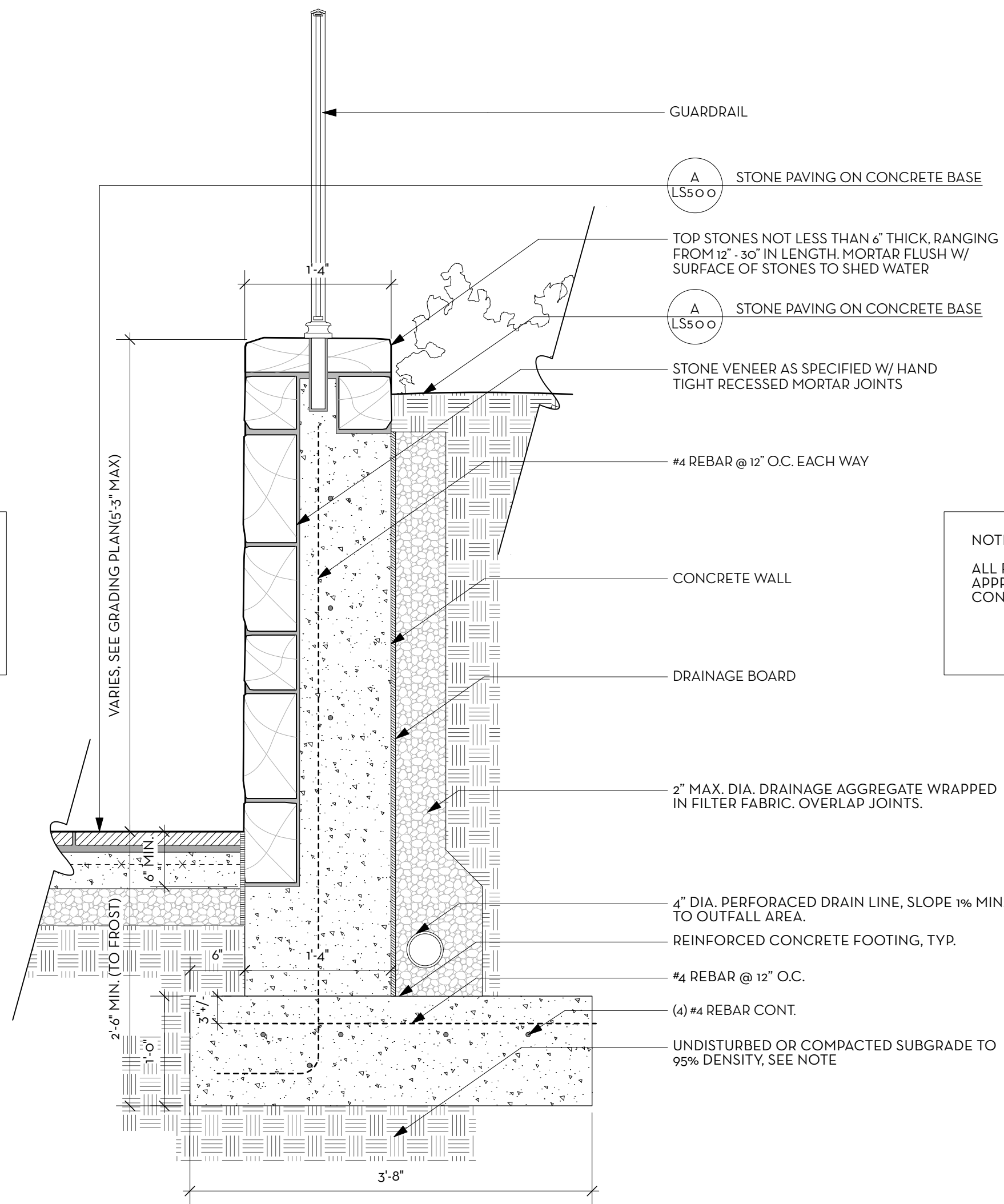

NOTE:  
 ALL FOOTING SIZES AND REINFORCEMENT TO BE APPROVED BY STRUCTURAL ENGINEER PRIOR TO CONSTRUCTION.

B2 STONE RETAINING WALL - CONDITION B  
 Scale: 1" = 1'-0"

APPROVED  
 Montgomery County  
 Historic Preservation Commission  
*[Signature]*

**REVIEWED**  
 By Dan.Bruechert at 4:20 pm, Sep 14, 2023

Consultants:

This drawing and the design shown hereon are the property of Campion Hruby Landscape Architects. The reproduction, copying or use of this drawing without written consent is prohibited and any infringement will be subject to legal action.

Project #: 22155

KATZ RESIDENCE

7 W. Kirke Street  
 Chevy Chase, MD 20815

10 AUGUST 2023

PERMIT DOCUMENT

No.	Date	Description

Drawn By: MC Proj. Manager: LP  
 Approved By: KC

Scale: AS SHOWN

HARDSCAPE DETAILS  
 - WALLS, STEPS, PIERS



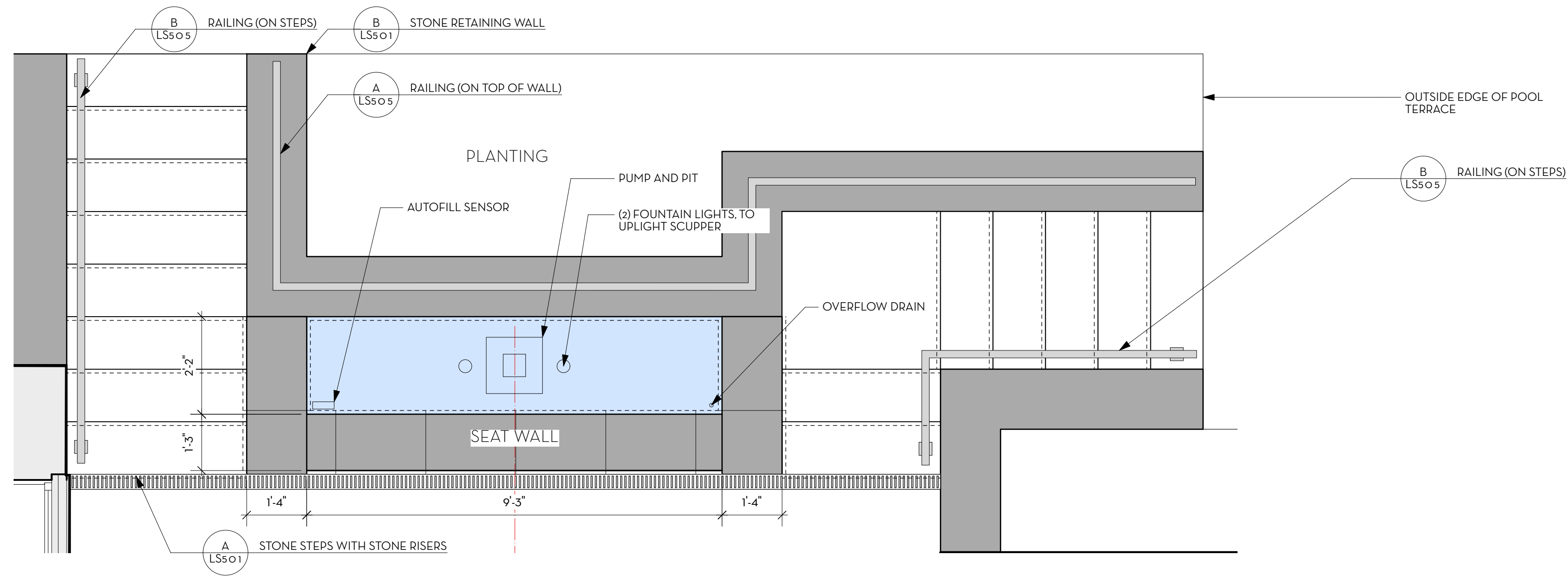

PLAN VIEW  
Scale: 1/2" = 1'-0"

NOTE:  
 1. ALL FOOTING SIZES AND REINFORCEMENT TO BE APPROVED BY STRUCTURAL ENGINEER PRIOR TO CONSTRUCTION.  
 2. CONTRACTOR TO SUBMIT SHOP DRAWINGS FOR LANDSCAPE ARCHITECT APPROVAL PRIOR TO CONSTRUCTION.  
 3. WATERLINE TILE  
 MANUFACTURER: CLASSIC POOL TILE  
 PRODUCT: CT SLT 80 NATURAL SLATE  
 COLOR: GREY  
 SIZE: 6" X 6"  
 4. FOUNTAIN BASIN FINISH TO BE DARK GREY OR BLACK WATERPROOFING.  
 NOTE: CONTRACTOR TO PROVIDE TILE AND FINISH SAMPLES FOR LANDSCAPE ARCHITECT APPROVAL PRIOR TO INSTALLATION.

APPROVED  
 Montgomery County  
 Historic Preservation Commission

*Ronald W. Norton*

REVIEWED  
 By Dan.Bruechert at 4:20 pm, Sep 14, 2023

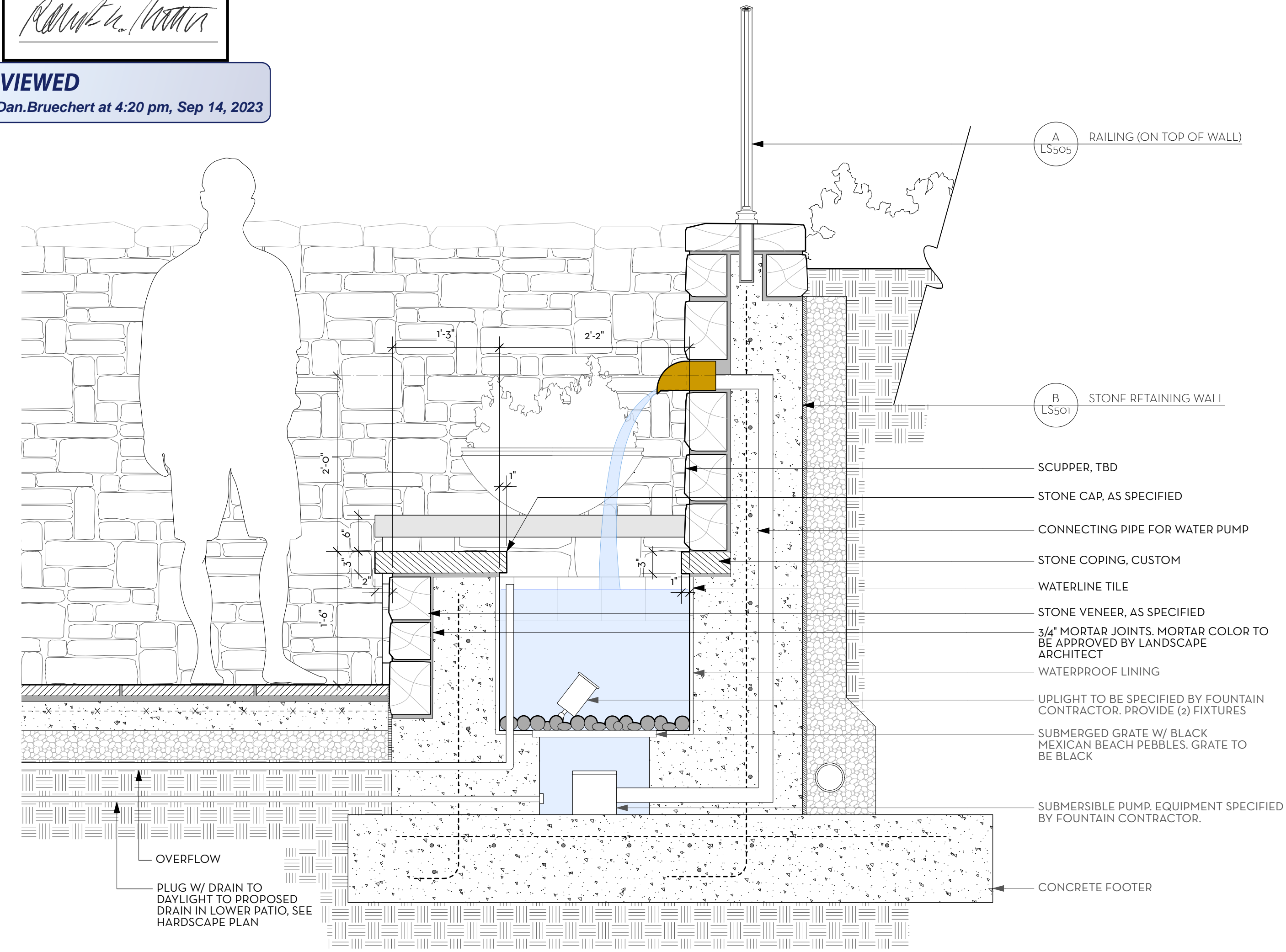

SECTION VIEW

A WATER FEATURE  
 Scale: 1" = 1'-0"

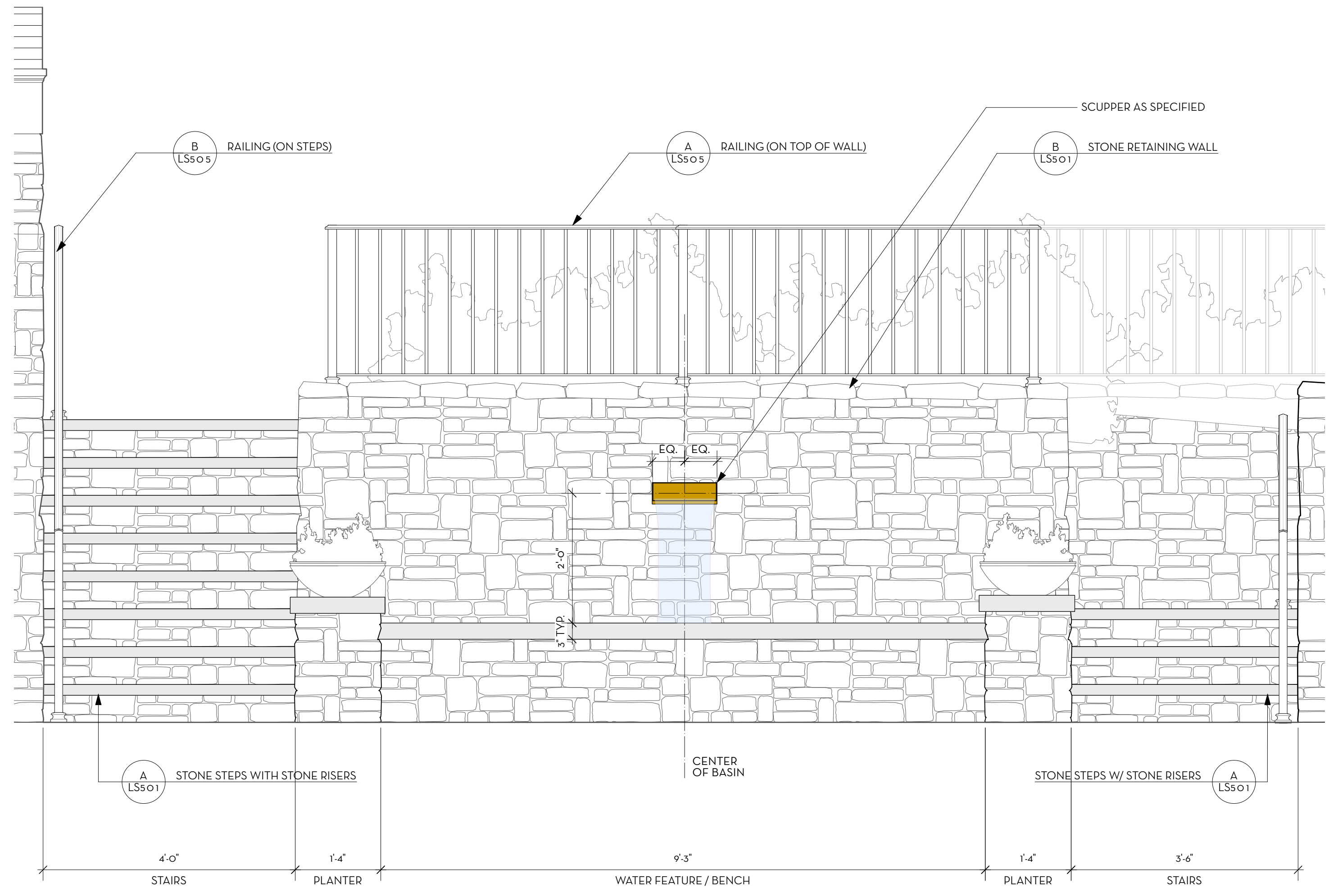

ELEVATION VIEW  
 Scale: 3/4" = 1'-0"

Consultants:  
 \_\_\_\_\_  
 \_\_\_\_\_  
 \_\_\_\_\_

This drawing and the design shown hereon are the property of Campion Hruby Landscape Architects. The reproduction, copying or use of this drawing without written consent is prohibited and any infringement will be subject to legal action.

Project #: 22155  
**KATZ RESIDENCE**  
 7 W. Kirke Street  
 Chevy Chase, MD 20815  
 10 AUGUST 2023

PERMIT DOCUMENT

No.	Date	Description

Drawn By: MC Proj. Manager: LP  
 Approved By: KC

Scale: AS SHOWN  
**HARDSCAPE DETAILS**  
**- WATER FEATURE**

**LS503**

If this drawing is not 24" x 36", it is a reduced print, and notations of scale no longer apply.  
 If this drawings is 12" x 18", it is a 50% reduced print, and scaled dimensions need to be multiplied by a factor of 2.

NOTE:

CONTRACTOR TO SUBMIT SHOP DRAWINGS FOR APPROVAL BY LANDSCAPE ARCHITECT PRIOR TO CONSTRUCTION

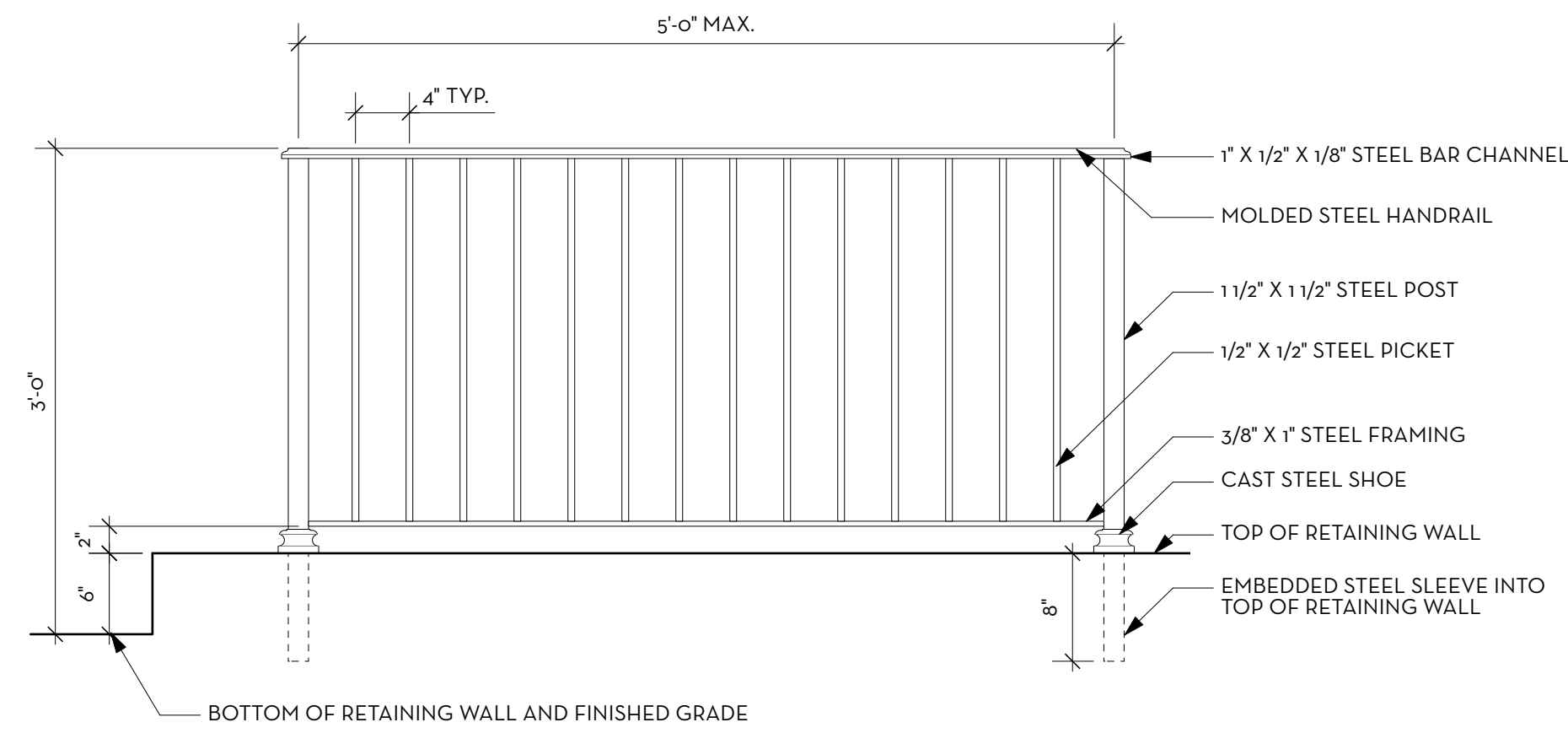

A RAILING (ON TOP OF WALL)  
Scale: 1" = 1'-0"

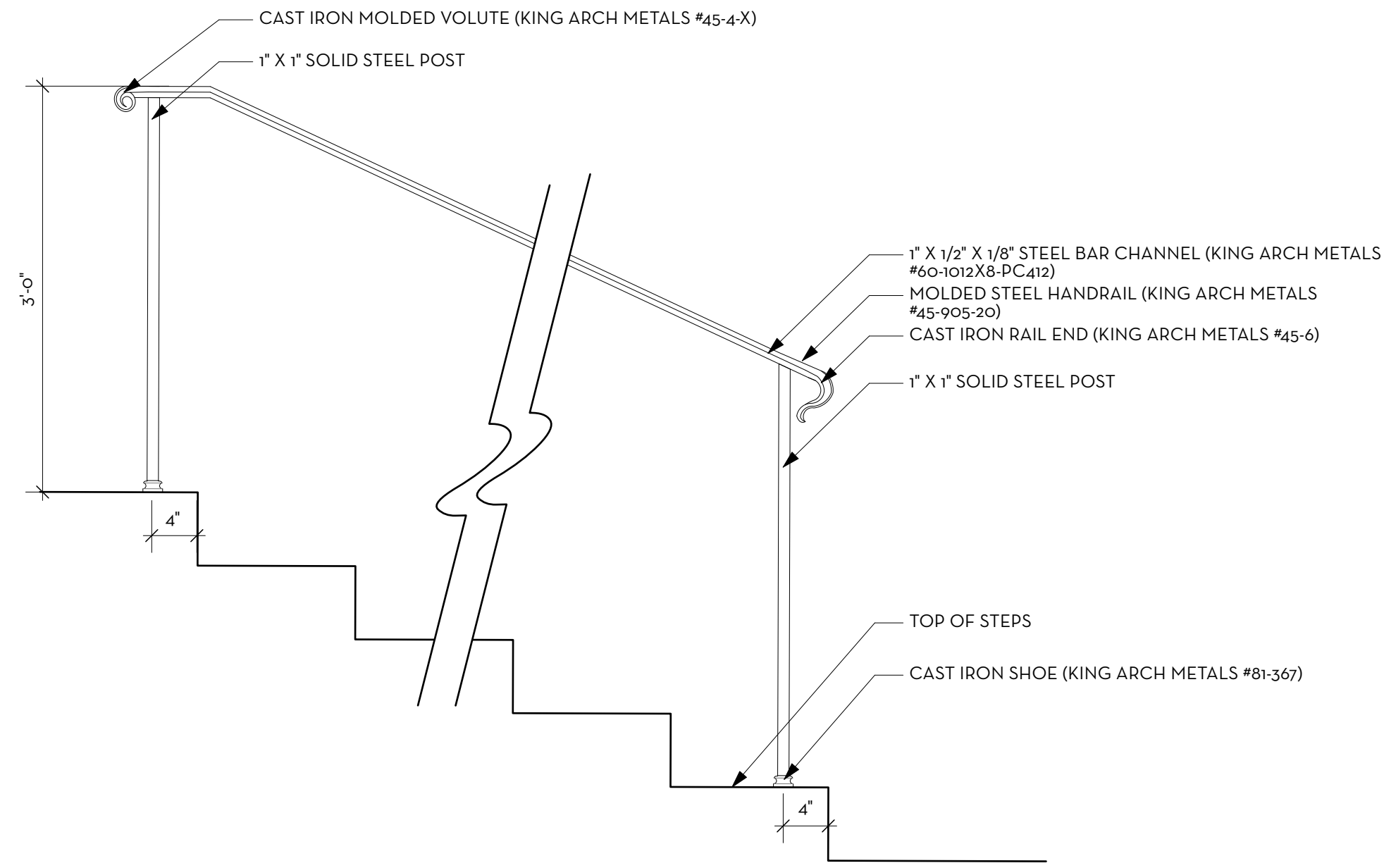

B RAILING (ON STEPS)  
Scale: 1" = 1'-0"

APPROVED  
Montgomery County  
Historic Preservation Commission

*Ronald L. [Signature]*

**REVIEWED**  
By Dan.Bruechert at 4:20 pm, Sep 14, 2023

CHLA

CAMPION/HRUBY

111 Cathedral Street, Suite 100 | Annapolis, MD 21401

O: 410.280.8850 campionhruby.com

Consultants:

This drawing and the design shown hereon are the property of Campion Hruby Landscape Architects. The reproduction, copying or use of this drawing without written consent is prohibited and any infringement will be subject to legal action.

Project #: 22155

KATZ  
RESIDENCE

7 W. Kirke Street  
Chevy Chase, MD 20815

10 AUGUST 2023

PERMIT DOCUMENT

No.	Date	Description

Drawn By: MC Proj. Manager: LP  
Approved By: KC

Scale: AS SHOWN

HARDSCAPE DETAILS  
- METAL

LS505