



HISTORIC PRESERVATION COMMISSION

Mark Elrich
County Executive

William Kirwan
Chairman

Date: January 24, 2019

MEMORANDUM

TO: Diane Schwartz Jones
Department of Permitting Services

FROM: Dan Bruechert
Historic Preservation Section
Maryland-National Capital Park & Planning Commission

SUBJECT: Historic Area Work Permit: Guardrail Construction

The Montgomery County Historic Preservation Commission (HPC) has reviewed the attached application for a Historic Area Work Permit (HAWP). This application was **Approved** at the January 9, 2019 Historic Preservation Commission meeting.

The HPC staff has reviewed and stamped the attached construction drawings.

THE BUILDING PERMIT FOR THIS PROJECT SHALL BE ISSUED CONDITIONAL UPON ADHERENCE TO THE ABOVE APPROVED HAWP CONDITIONS AND MAY REQUIRE APPROVAL BY DPS OR ANOTHER LOCAL OFFICE BEFORE WORK CAN BEGIN.

Applicant: M-NCPPC (Montgomery Parks)
Address: 17210 Bucklodge Rd., Boyds

This HAWP approval is subject to the general condition that the applicant will obtain all other applicable Montgomery County or local government agency permits. After the issuance of these permits, the applicant must contact this Historic Preservation Office if any changes to the approved plan are made. Once work is complete the applicant will contact Dan Bruechert at 301.563.3408 or dan.bruechert@montgomeryplanning.org to schedule a follow-up site visit.





Imagery ©2018 Google, Map data ©2018 Google 500 ft

APPROVED
 Montgomery County
 Historic Preservation Commission

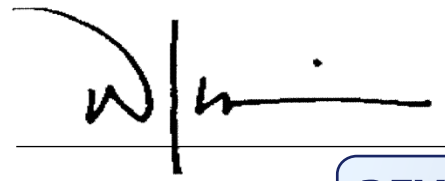

Joseph White House

Historic Envisionmental Setting

Dotted line - Easement boundary

REVIEWED
 By Dan.Bruechert at 12:04 pm, Jan 24, 2019

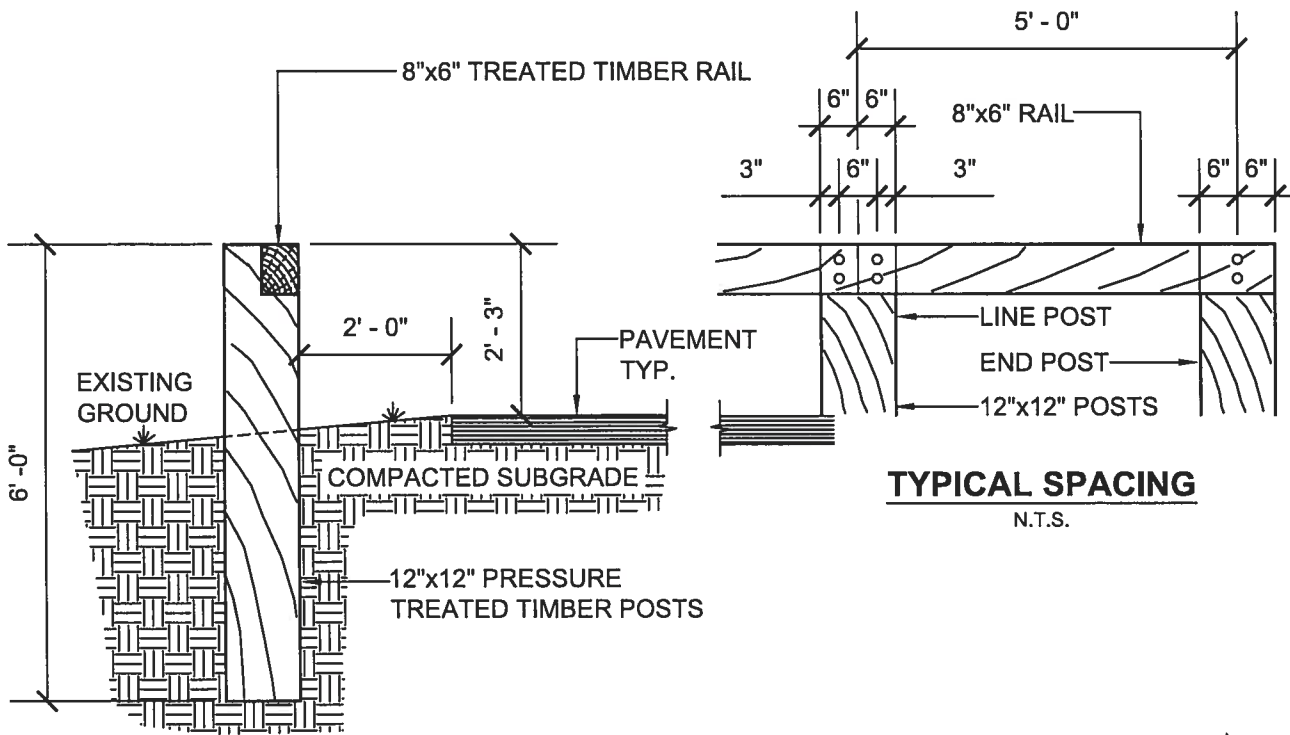

TYPICAL PLACEMENT
N.T.S.

TYPICAL SPACING
N.T.S.

5/8" DIA.x12" CARRIAGE BOLTS WITH HEX NUTS AND CUT WASHERS SET IN RECESS

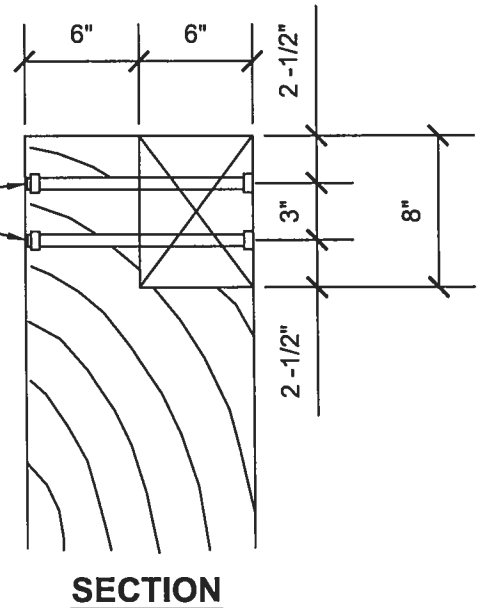
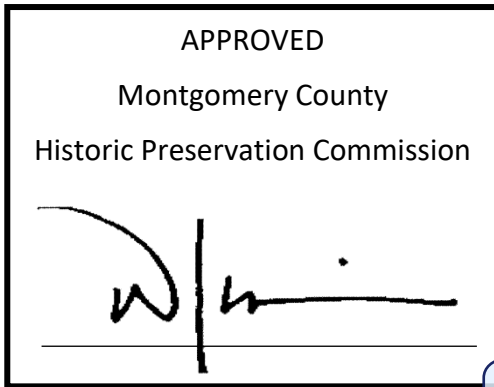

SECTION
N.T.S.

NOTES:

1. TIMBER USED IN GUARD RAIL SHALL BE ROUND PULPWOOD (R.P.W.) OR PINE (PENTACHLORO- % #/CF), AWPA PHENOL @ 0.50 STANDARD P5 (COPPER ARSENATE % #/CF) OR TIMBER MAY BE @ 0.50 WOLMANIZED.
2. ALL FASTENER HARDWARE SHALL BE GALVANIZED. BOLTS SHALL CONFORM TO ASTM A307.
3. POST TO BE PLACED IN MECHANICALLY OR HAND-AUGERED HOLE AND SECURELY TAMPED.
4. CONCRETE, IF USED, SHALL BE MSHA MIX No. 2 (3000 PSI).

REVIEWED

By Dan.Bruechert at 12:04 pm, Jan 24, 2019

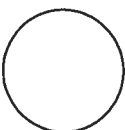

TIMBER GUARD RAIL

The Maryland-National Capital Park and Planning Commission
Montgomery County Department of Parks

Detail No.

431

9 AUGUST 2007



North side of the culvert (open horse gate on right). Millings to be removed and grass restored following completion of construction work. House is located beyond the photo to the upper left-hand corner.

APPROVED
Montgomery County
Historic Preservation Commission

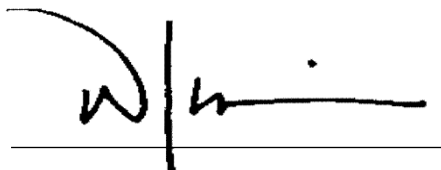

REVIEWED
By Dan.Bruechert at 12:04 pm, Jan 24, 2019



Photo of extant guardrail at Black Hills Regional Park as example of what is proposed at this site.

APPROVED
Montgomery County
Historic Preservation Commission

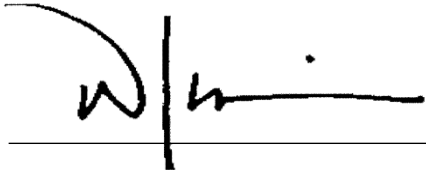
A handwritten signature in black ink, appearing to be 'W/n', is written over a horizontal line.

REVIEWED
By Dan.Bruechert at 12:04 pm, Jan 24, 2019