



## HISTORIC PRESERVATION COMMISSION

Marc Elrich  
*County Executive*

Robert Sutton  
*Chairman*

Date: July 25, 2024

### MEMORANDUM

TO: Rabbiah Sabbakhan  
Department of Permitting Services

FROM: Chris Berger  
Historic Preservation Section  
Maryland-National Capital Park & Planning Commission

SUBJECT: Historic Area Work Permit # 1076695 - Installation of Replacement Luminaires on Lamp Posts

---

The Montgomery County Historic Preservation Commission (HPC) has reviewed the attached application for a Historic Area Work Permit (HAWP). This application was **approved** at the July 24, 2024, HPC meeting.

The HPC staff has reviewed and stamped the attached construction drawings.

THE BUILDING PERMIT FOR THIS PROJECT SHALL BE ISSUED CONDITIONAL UPON ADHERENCE TO THE ABOVE APPROVED HAWP CONDITIONS AND MAY REQUIRE APPROVAL BY DPS OR ANOTHER LOCAL OFFICE BEFORE WORK CAN BEGIN.

Applicant: Town of Brookeville (Andrea Scanlon, agent)  
Address: Various High, Market, and Water Streets

This HAWP approval is subject to the general condition that the applicant will obtain all other applicable Montgomery County or local government agency permits. After the issuance of these permits, the applicant must contact this Historic Preservation Office if any changes to the approved plan are made. Once work is complete the applicant will contact Chris Berger at 301-495-4571 or [chris.berger@montgomeryplanning.org](mailto:chris.berger@montgomeryplanning.org) to schedule a follow-up site visit.





FOR STAFF ONLY:  
HAWP# \_\_\_\_\_  
DATE ASSIGNED \_\_\_\_\_

# APPLICATION FOR HISTORIC AREA WORK PERMIT

HISTORIC PRESERVATION COMMISSION  
301.563.3400

**APPLICANT:**

Name: \_\_\_\_\_ E-mail: \_\_\_\_\_  
Address: \_\_\_\_\_ City: \_\_\_\_\_ Zip: \_\_\_\_\_  
Daytime Phone: \_\_\_\_\_ Tax Account No.: \_\_\_\_\_

**AGENT/CONTACT (if applicable):**

Name: \_\_\_\_\_ E-mail: \_\_\_\_\_  
Address: \_\_\_\_\_ City: \_\_\_\_\_ Zip: \_\_\_\_\_  
Daytime Phone: \_\_\_\_\_ Contractor Registration No.: \_\_\_\_\_

**LOCATION OF BUILDING/PREMISE:** MIHP # of Historic Property \_\_\_\_\_

Is the Property Located within an Historic District?  Yes/District Name \_\_\_\_\_  
 No/Individual Site Name \_\_\_\_\_

**REVIEWED**

By Chris Berger at 1:02 pm, Jul 25, 2024

Historic Preservation/Land Trust, Environmental Easement on the Property? If YES, include a map of the easement, and documentation from the Easement Holder supporting this application.

Are other Planning and/or Hearing Examiner Approvals /Reviews Required as part of this Application? (Plat, etc.?) If YES, include information on these reviews as

APPROVED  
Montgomery County  
Historic Preservation Commission

Street: \_\_\_\_\_  
Nearest Cross Street: \_\_\_\_\_  
Subdivision: \_\_\_\_\_ Parcel: \_\_\_\_\_

**the checklist on Page 4 to verify that all supporting items for proposed work are submitted with this application. Incomplete Applications will not be accepted for review. Check all that apply:**

- New Construction
- Addition
- Demolition
- Grading/Excavation
- Deck/Porch
- Fence
- Hardscape/Landscape
- Roof
- Shed/Garage/Accessory Structure
- Solar
- Tree removal/planting
- Window/Door
- Other: \_\_\_\_\_

I hereby certify that I have the authority to make the foregoing application, that the application is correct and accurate and that the construction will comply with plans reviewed and approved by all necessary agencies and hereby acknowledge and accept this to be a condition for the issuance of this permit.

Signature of owner or authorized agent

Date

**HAWP APPLICATION: MAILING ADDRESSES FOR NOTIFYING**  
[Owner, Owner's Agent, Adjacent and Confronting Property Owners]

**Owner's mailing address**

**Owner's Agent's mailing address**

**Adjacent and confronting Property Owners mailing addresses**

**REVIEWED**

*By Chris Berger at 1:02 pm, Jul 25, 2024*

APPROVED

Montgomery County

Historic Preservation Commission



Robert H. Adams

Town of Brookeville  
Adjacent Property Owners List

Brookeville, MD 20833

First Name	Last Name	Business Name	Address
Jennier	Roy		108 Water St
Nicholas	Roy		108 Water St
Marti	Andress		106 Water St
Jeffrey	Johnson		106 Water St
Beth	Anderson		104 Water St
Garrett	Anderson		104 Water St
Iris	Stratton		1 South St
Donald	De Wall		1 South St
Allison	Moffett		1 North St
Bryan	Moffett		1 North St
Bill	Gaskill		2 North St
Patience	Gaskill		2 North St
Teresa	Pollock		4 North St
Matt	Pollock		4 North St
Teresa	Meeks		9 North St
Fred	Teal		9 North St
Mark	Davis		13 North St
Nathalie	Davis		13 North St
Dan	Donnelly		17 North
Carys	Donnelly		17 North
Chloe	Batch		198 Market St
Andrea	Batch		198 Market St
Claire	Fuller		200 Market
	Fuller		200Market
Phyllis	Millard		202 Market St
Andrea	Scanlon		203 Market St
Chris	Scanlon		203 Market St
Bruce	Evans		204 Market St
Toni	Evans		204 Market St
Duane	Heiler		205 Market St
Sandra	Heiler		205 Market St
Daniel	Heyman		206 Market St
Kim	Heyman		206 Market St
Warren	Ferris		207 Market St
Renee	Moneyhun		207 Market St
Miche	Booz		208 Market St
Diane	Teague		208 Market St
Michael	Acierno		209 Market St
Harper	Pryor		209 Market St
Jessica	Schwartz		210 Market St
Geoff	Harshman		210 Market St
Karen	Montgomery		211 Market St
Todd	Van Gelder		212 Market St
Chris	Haris		301 Market St
Micole	Haris		301 Market St
Arun	Deonarain		306 Market St
Stephanie	Deonarain		306 Market St
Dee	Heritage		307 Market St
Mike	Oestreich		308 Market St
Sara	Oestreich		308 Market St

**REVIEWED**  
By Chris Berger at 1:02 pm, Jul 25, 2024

APPROVED  
Montgomery County  
Historic Preservation Commission



		First National Assets	309 Market St
Hannah	Kerr		310 Market St
Steff	Kerr		310 Market St
Deeds	Wells		311 Market St
Barbara	Achstettes		312 Market St
Jeff	Issokson		313 Market St
Margaret	Kay		313 Market St
Joanne	Keister		314 Market St
Anne	Ennes		316 Market St
Mark	Ennes		316 Market St
William	Kiniry		318 Market St
Suzanna	Moreau		318 Market St
Saj	Niazi		1 High
Dan	Ennis		2 High St
Cindy	Ennis		2 High St
Jennier	Falkinburg		3 High St
		Brookeville Academy	5 High St
			6 High St
Emily	Hart		8 High St
Chris	Hart		8 High St
Michael	Murphy		9 High St
		Orndorff Hall	10 High St
		Salem United Methodist Church	12 High St
Mary Kay	Spagnolo		14 High St
Andrew	Spagnolo		14 High St
Tim	Hussman		15 High St
Julie	Hussman		15 High St
Lori	Laughlin		16 High St
Daniel	Laughlin		16 High St
Taddeo	Kintu		18 High St
Tiona	Kintu		18 High St
Cate	McDonald		20 High St
Jenny	Bowker		22 High St
Shirley	Bowker		22 High St
Kathy	Hawkins		24 High St
Curtis	Michael		26 High St
Stefan	Syski		28 High St
Valerie	Syski		28 High St
		MNCPPC	19801 Georgia Ave
Becky	Jackson		1 Church St
Mary Ellen	Eaton		1 Church St
Alan	Breece		3 Church St
Buck	Bartley		5 Church St
Patricia	Thompson		7 Church St
Donald	Thompson		7 Church St

**REVIEWED**

*By Chris Berger at 1:02 pm, Jul 25, 2024*

APPROVED

Montgomery County

Historic Preservation Commission



**Description of Property:** Please describe the building and surrounding environment. Include information on significant structures, landscape features, or other significant features of the property:

**Description of Work Proposed:** Please give an overview of the work to be undertaken:

**REVIEWED**

*By Chris Berger at 1:02 pm, Jul 25, 2024*

APPROVED

Montgomery County

Historic Preservation Commission



Robert H. Adams

Work Item 1: \_\_\_\_\_

Description of Current Condition:	Proposed Work:
-----------------------------------	----------------

Work Item 2: \_\_\_\_\_

Description of Current Condition:	Proposed Work:
-----------------------------------	----------------

Work Item 3: \_\_\_\_\_

Description of Current Condition:	<div data-bbox="649 1423 1312 1549" data-label="Text"><p><b>REVIEWED</b> By Chris Berger at 1:02 pm, Jul 25, 2024</p></div> <div data-bbox="698 1591 1188 1974" data-label="Text"><p>APPROVED Montgomery County Historic Preservation Commission</p><hr/></div>
-----------------------------------	---





**REVIEWED**  
By Chris Berger at 1:02 pm, Jul 25, 2024

APPROVED  
Montgomery County  
Historic Preservation Commission  

Town of Brookeville  
HAWP Application  
July 2, 2024  
Photo 1 - Existing Streetlight





**REVIEWED**

*By Chris Berger at 1:02 pm, Jul 25, 2024*

APPROVED

Montgomery County

Historic Preservation Commission

Town of Brookeville  
HAWP Application  
July 2, 2024

Photo 2 - Existing Luminaire





**REVIEWED**  
By Chris Berger at 1:02 pm, Jul 25, 2024

APPROVED  
Montgomery County  
Historic Preservation Commission  
*Robert H. [Signature]*

This drawing is property of Spring City Elect. Mfg. and is issued to the recipient with the understanding that it shall not be copied, duplicated, passed on to unauthorized parties, nor used for any purpose other than that for which it is specifically furnished except with Spring City's written permission.

**REVIEWED**

By Chris Berger at 1:02 pm, Jul 25, 2024

APPROVED  
 Montgomery County  
 Historic Preservation Commission

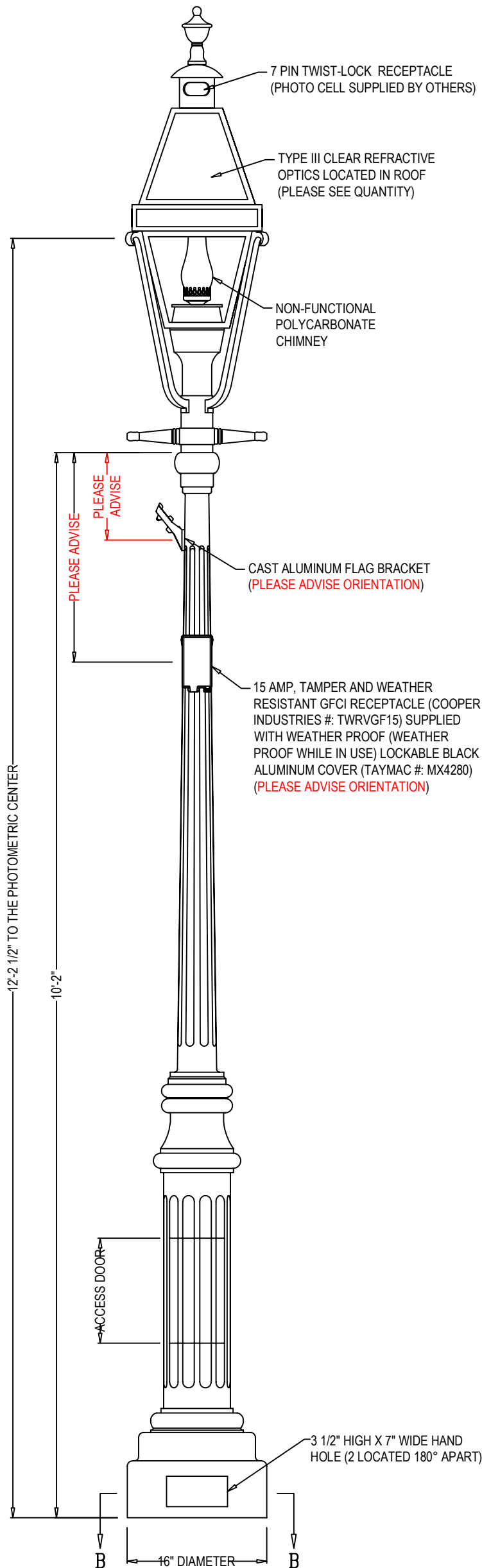
**LUMINAIRE SPECIFICATIONS**

STYLE: JEFFERSON (WITH LADDER REST AND FRANKLIN GOOSENECK FINIAL)  
 HEIGHT: 49"  
 WIDTH: 17"  
 MATERIAL: CAST ALUMINUM  
 PANELS: SEEDED ACRYLIC PANELS  
 FINISH: POWDER COAT - RIVER TEXTURE GLOSS BLACK  
 LAMPING: 50 WATT LED SYSTEM  
 VOLTAGE: ELECTRONICALLY WIRED AT 120-277 VOLTS  
 COLOR TEMP.: 2200K (GOLDEN WHITE)  
 DISTRIBUTION: TYPE III CLEAR REFRACTIVE OPTICS (ASYMMETRIC DISTRIBUTION)  
 MODIFIER: - 7 PIN TWIST LOCK RECEPTACLE ONLY (PHOTO CELL BY OTHERS)  
 - NON-FUNCTIONAL WHITE POLYCARBONATE CHIMNEY  
 - FRANKLIN GOOSENECK VENT CAP WITH JEFFERSON FINIAL  
 - INTEGRATED LADDER REST

CATALOG NO.: ALMJFF-LE050-EVX-2G3-22-CR3-YSDP-CMP-FRG-FJF-TR7P-LR-CU

**LAMP POST SPECIFICATIONS**

STYLE: HANCOCK (INTERNAL ANCHOR BOLTS)  
 HEIGHT: 10'-2"  
 PHOTOMETRIC CENTER: 12'-2 1/2"  
 BASE: 16" DIAMETER  
 MATERIAL: ONE PIECE, HEAVY WALL CAST IRON  
 PER A.S.T.M. A 48-83 CLASS 30  
 FINISH: POWDER COAT - RIVER TEXTURE GLOSS BLACK  
 ACCESS DOOR: LOCATED IN BASE SECURED WITH TAMPER PROOF  
 HEX SOCKET SECURITY MACHINE SCREWS  
 GROUND PROVISIONS: DRILL AND TAP WALL OPPOSITE ACCESS DOOR TO ACCOMMODATE  
 A 1/4"-20 GROUND STUD (GROUND STUD SUPPLIED BY OTHERS)  
 ANCHOR BOLTS: (4) 3/4" DIA. (SUPPLIED BY OTHERS)  
 BOLT PROJECTION: 3" REQUIRED  
 TENON: 2 7/8" DIA. X 3" HIGH (TO ACCEPT LUMINAIRE)

CATALOG NO.: IPSHNC-16-10.17-TN2.88-3.00-FH-GFWI-CU  
 POST:  
 ANCHOR BOLTS: 999/0NW

QUANTITY ..... XX REQUIRED  
 PER S.O. #: XXXXXX

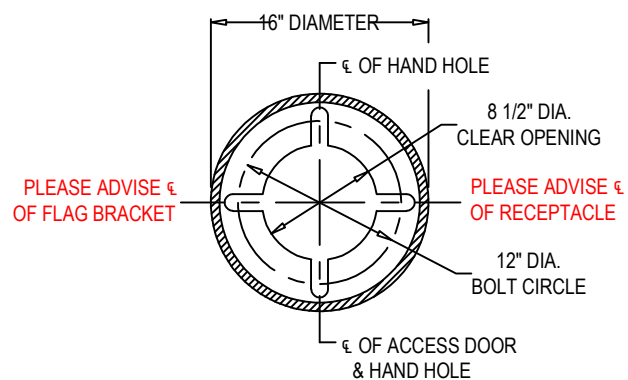

SECTION B-B  
 N.T.S.



**Spring City Electrical Mfg. Co.**

HALL AND MAIN STREETS - P.O. BOX 19 - SPRING CITY, PA. 19475  
 PHONE (610) 948-4000 - FAX (610) 948-5577 - WWW.SPRINGCITY.COM

DESCRIPTION	THE 10'-2" HANCOCK (INTERNAL ANCHOR BOLT) IRON LAMP POST WITH THE JEFFERSON LUMINAIRE AND LADDER REST		
OPPORTUNITY	BROOKVILLE MD, RELIGHT		
SCALE	DRAWN BY:	DATE	DRAWING NO.
N.T.S.	J.H.P.	02-22-24	SPEC-34640



This drawing is property of Spring City Elect. Mfg. and is issued to the recipient with the understanding that it shall not be copied, duplicated, passed on to unauthorized parties, nor used for any purpose other than that for which it is specifically furnished except with Spring City's written permission.

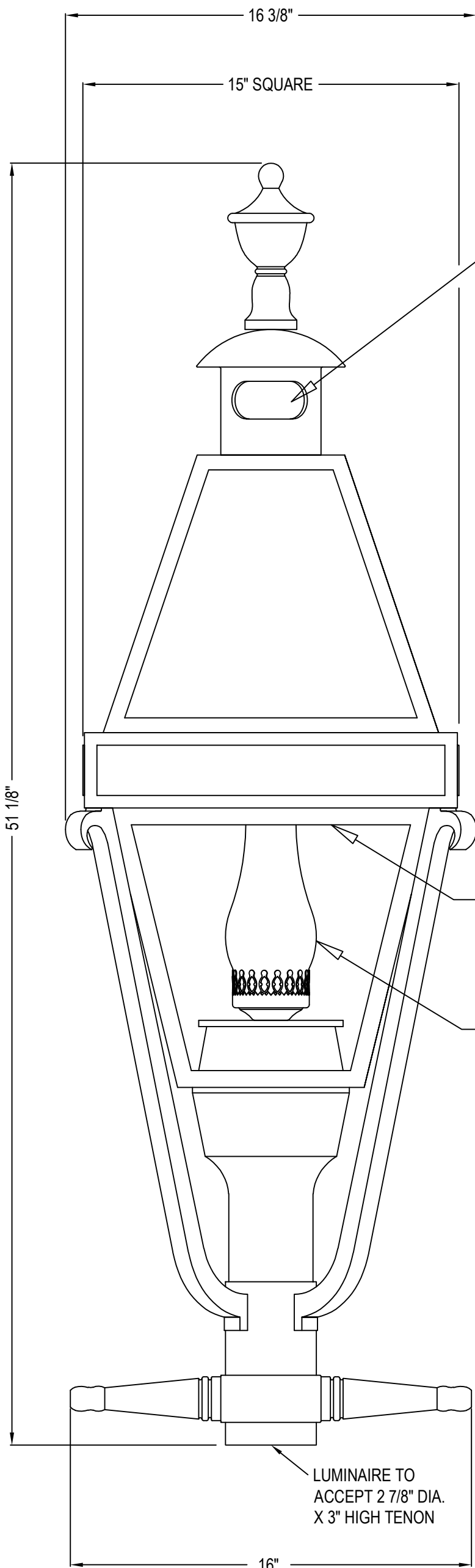

7 PIN TWIST-LOCK RECEPTACLE (PHOTO CELL SUPPLIED BY OTHERS)

**LUMINAIRE SPECIFICATIONS**

STYLE: JEFFERSON (WITH LADDER REST AND FRANKLIN GOOSENECK FINIAL)  
 HEIGHT: 49"  
 WIDTH: 17"  
 MATERIAL: CAST ALUMINUM  
 PANELS: SEEDED ACRYLIC PANELS  
 FINISH: POWDER COAT - RIVER TEXTURE GLOSS BLACK  
 LAMPING: 50 WATT LED SYSTEM  
 VOLTAGE: ELECTRONICALLY WIRED AT 120-277 VOLTS  
 COLR TEMP.: 2200K (GOLDEN WHITE)  
 DISTRIBUTION: TYPE III CLEAR REFRACTIVE OPTICS (ASYMMETRIC DISTRIBUTION)  
 MODIFIER: - 7 PIN TWIST LOCK RECEPTACLE (PHOTO CELL BY OTHERS)  
 - NON-FUNCTIONAL WHITE POLYCARBONATE CHIMNEY  
 - FRANKLIN GOOSENECK VENT CAP WITH JEFFERSON FINIAL  
 - INTEGRATED LADDER REST

CATALOG NO.: ALMJFF-LE050-EVX-2G3-22-CR3-YSDP-CMP-FRG-FJF-TR7P-LR-CU

QUANTITY ..... XX COMPLETE UNITS REQUIRED  
 PER S.O. # XXXXXX

TYPE III CLEAR REFRACTIVE OPTICS LOCATED IN ROOF (PLEASE SEE QUANTITY)

NON-FUNCTIONAL POLYCARBONATE CHIMNEY

LUMINAIRE TO ACCEPT 2 7/8" DIA. X 3" HIGH TENON

**REVIEWED**  
 By Chris Berger at 1:02 pm, Jul 25, 2024

APPROVED  
 Montgomery County  
 Historic Preservation Commission



 **Spring City Electrical Mfg. Co.**  
 HALL AND MAIN STREETS - P.O. BOX 19 - SPRING CITY, PA. 19475  
 PHONE (610) 948-4000 - FAX (610) 948-5577 - WWW.SPRINGCITY.COM

DESCRIPTION	THE JEFFERSON LED LUMINAIRE WITH INTEGRATED LADDER REST		
OPPORTUNITY	BROOKEVILLE MD, RELIGHT		
SCALE	DRAWN BY:	DATE	DRAWING NO.
N.T.S.	J.H.P.	02-22-2024	SPEC-34641

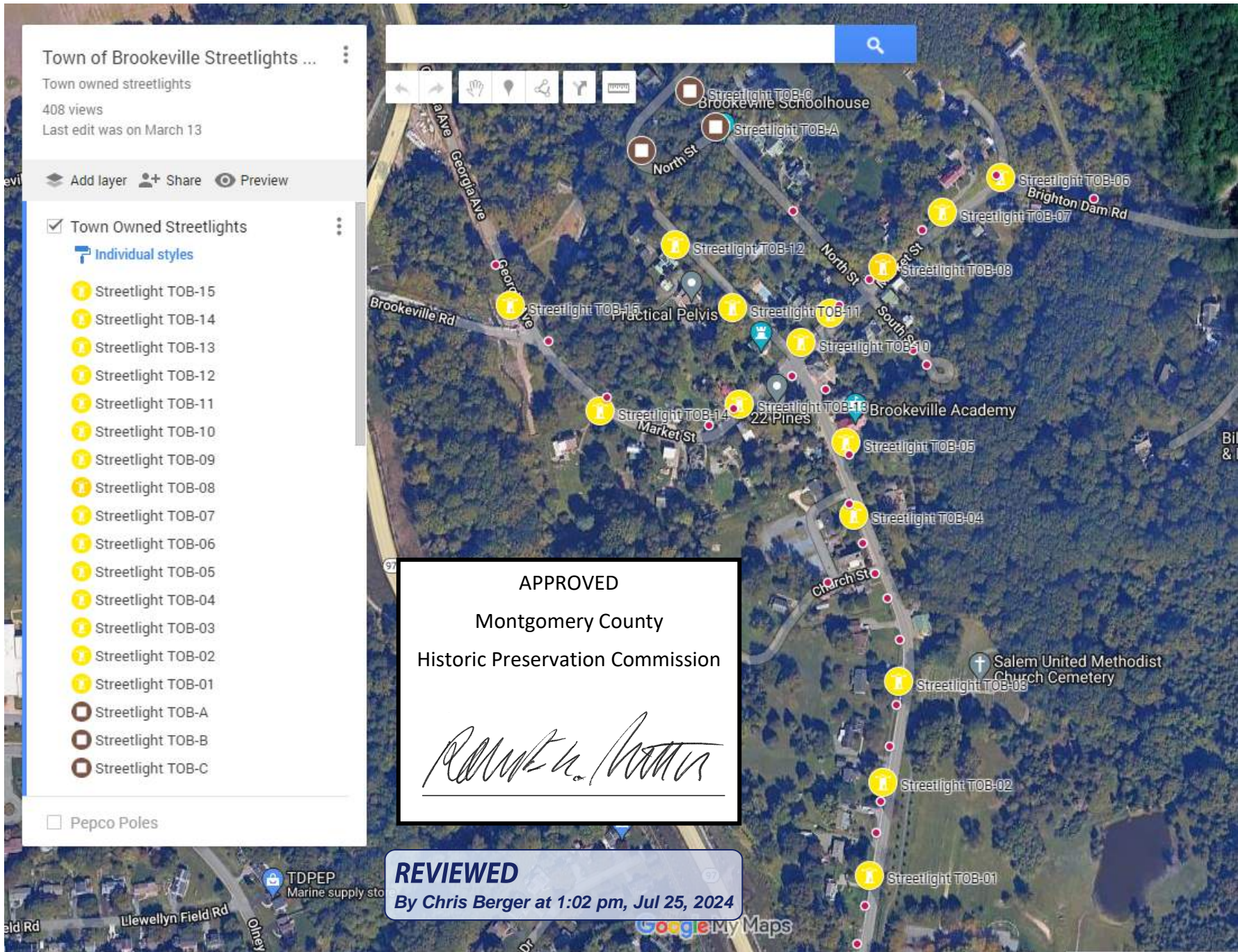

Replace luminaires on streetlights with cast iron poles  
 1-15 on High St, Market St, Water St  
 (no work on streetlights A-C with wood poles)

Town of Brookeville  
 Streetlight Location Map  
 July 2, 2024





DEPARTMENT OF PERMITTING SERVICES

Marc Elrich  
County Executive

Rabbiah Sabbakhan  
Director

# HISTORIC AREA WORK PERMIT APPLICATION

Application Date: 7/1/2024

Application No: 1076695  
AP Type: HISTORIC  
Customer No: 1363731

### Comments

Replace luminaires on existing fifteen (15) cast iron street light poles throughout the Town of Brookeville.

### Affidavit Acknowledgement

The Homeowner is the Primary applicant  
This application does not violate any covenants and deed restrictions

### Primary Applicant Information

Address 5 HIGH ST  
BROOKEVILLE, MD 20833  
Othercontact Scanlon (Primary)

Historic Area Work Permit Details  
**REVIEWED**  
By Chris Berger at 1:02 pm, Jul 25, 2024

APPROVED  
Montgomery County  
Historic Preservation Commission